

xTOOL

xTool Rotary Attachment 3 Lite

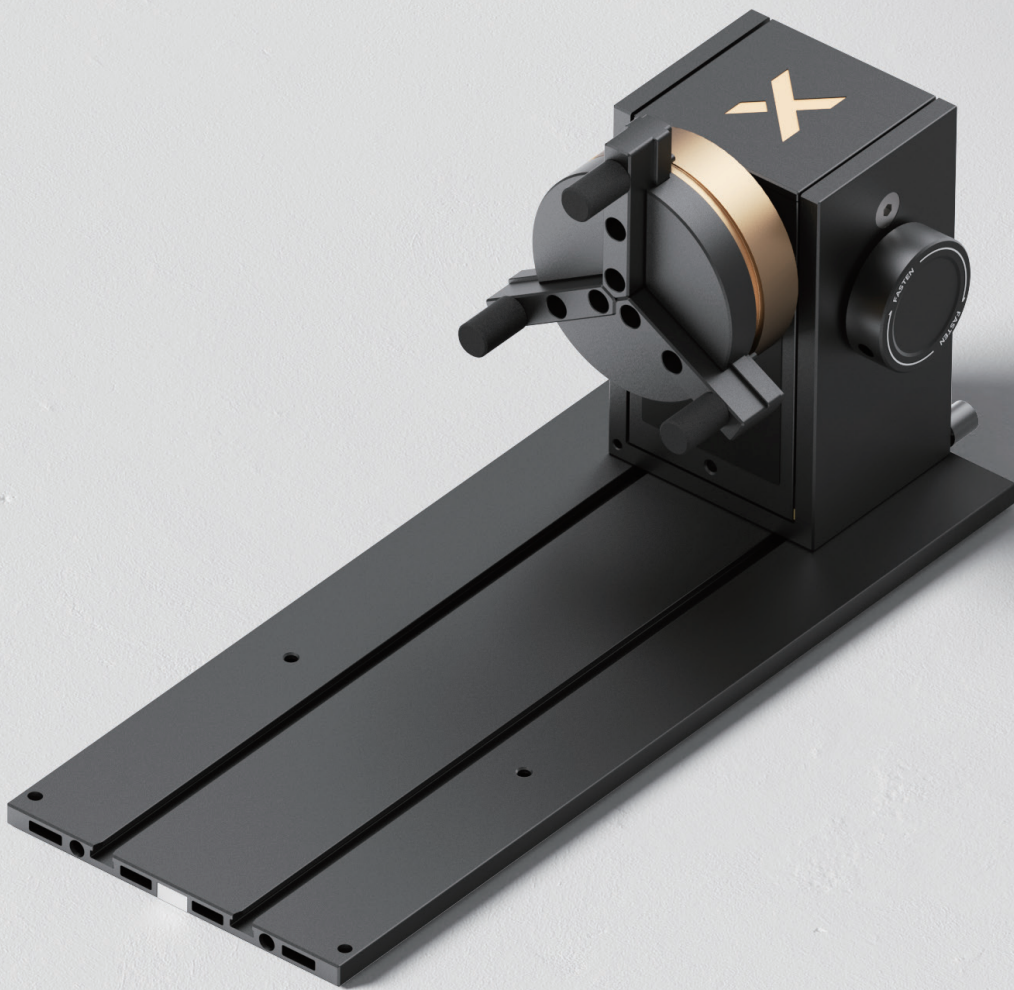

Quick Start Guide

Contents

Safety precautions	-----	01
List of items	-----	01
Use xTool Rotary Attachment 3 Lite	-----	02
Use with xTool M2	-----	08

Safety precautions

- The product features a magnetic quick-release design. Do not put your hand between magnetic parts during use to avoid pinching yourself. There is also a risk of pinching when assembling different modules, rotating the jaw chuck, and adjusting the power module and the support module.
- Keep the product away from children.
- Clean the product using a dry cloth.

List of items

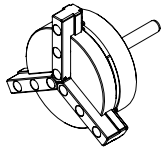

Jaw chuck

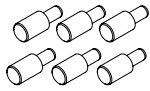

Cylindrical jaw



T-shaped jaw

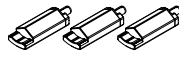

Extended jaw

Jaw chuck components

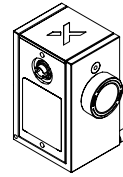

Power module

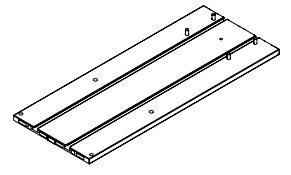

Main baseplate

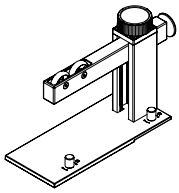

Support module

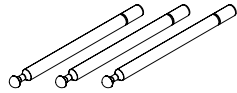

Stud components



Laser shield

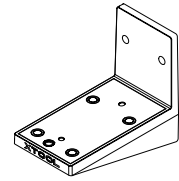

Horizontal laser emission holder

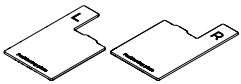

Positioning plate

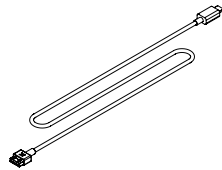

Device connection cable

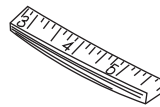

Tape measure



See support.xtool.com/article/1936 for details about how to use the tape measure.

Use xTool Rotary Attachment 3 Lite

Preparations

1 Fix the power module on the main baseplate.

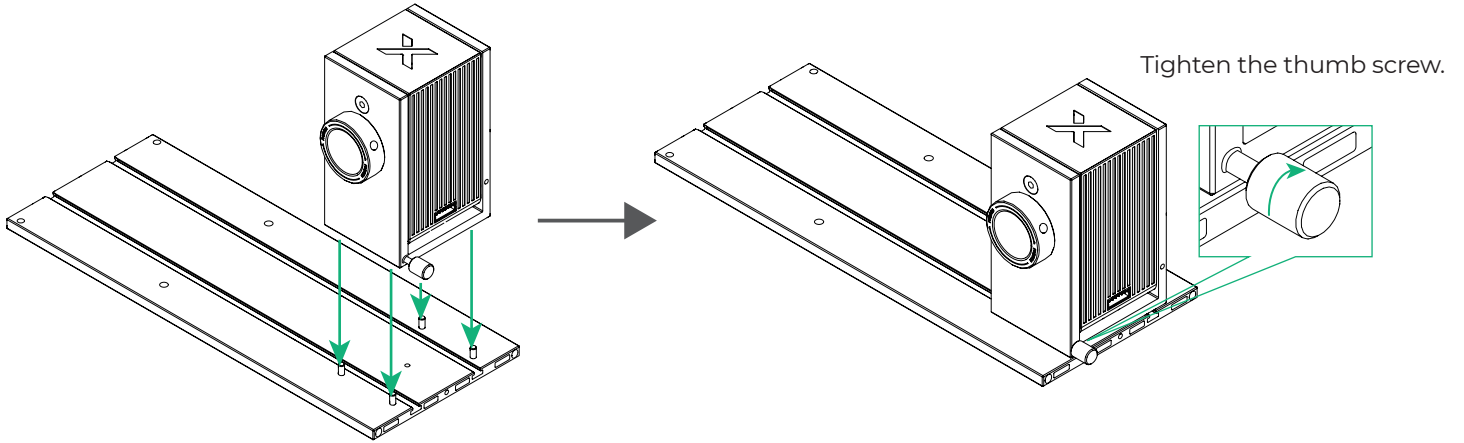
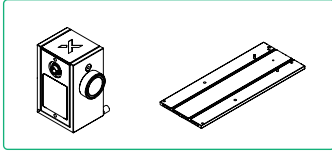

2 Assemble the jaw chuck components.

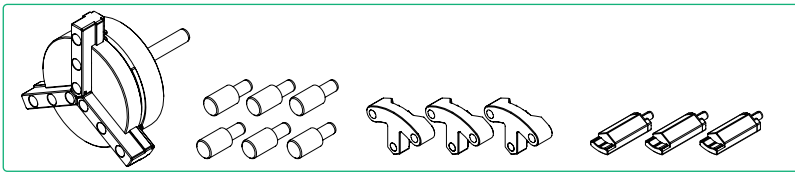

■ Method 1:
Suitable for processing common rotating workpieces

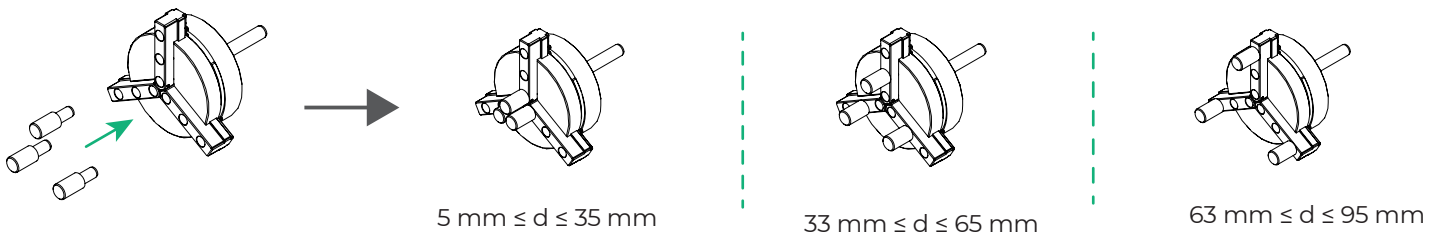

■ Method 2:
Suitable for processing large or smooth-surfaced rotating workpieces

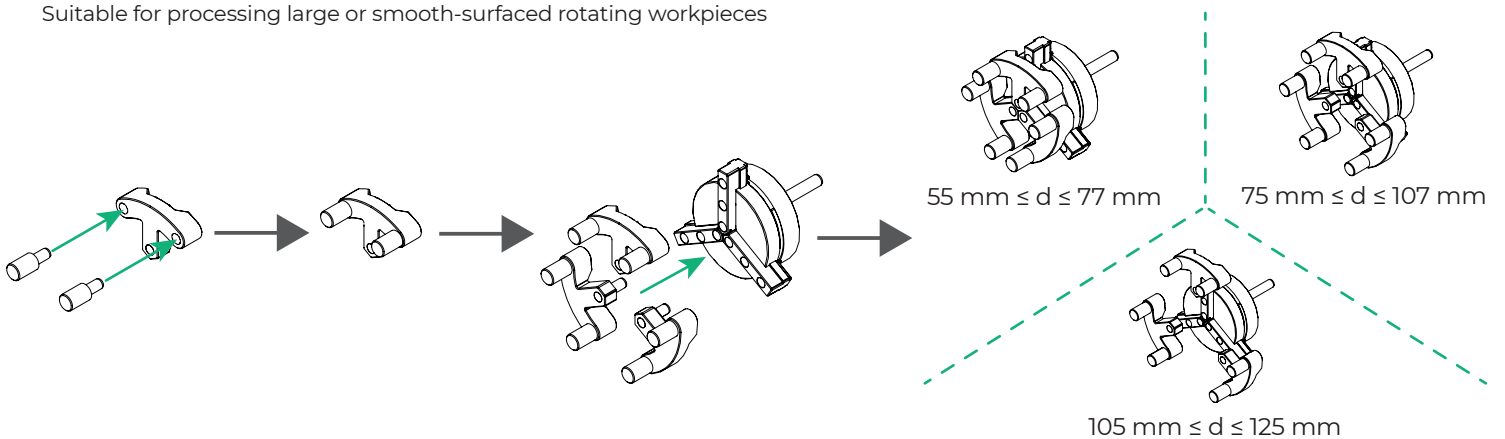

- Method 3:
Suitable for processing small or lightweight rotating workpieces

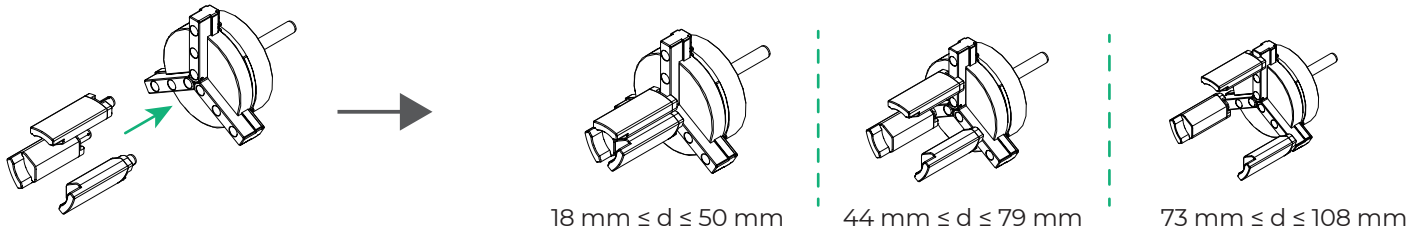

Process cylindrical objects

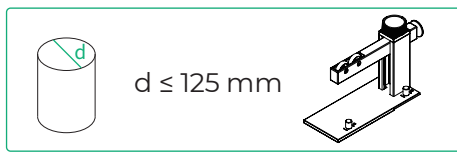

- 1 Put the workpiece on a table. Place the jaw chuck against the workpiece as illustrated, with its jaws surrounding the outside of the workpiece.

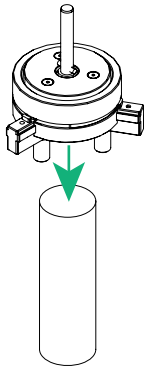

- 2 Rotate the knob to secure the workpiece.

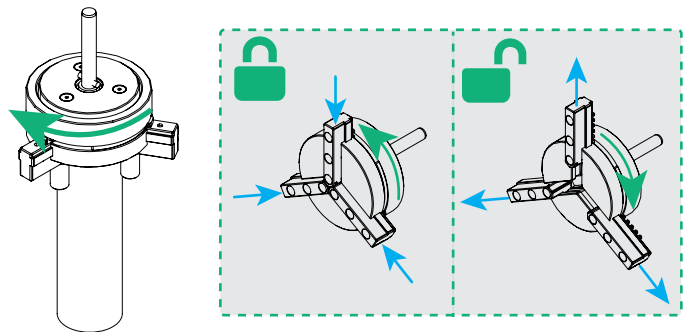

- 3 Insert the jaw chuck components into the power module.

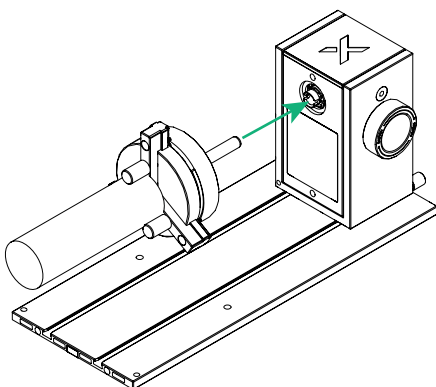

- 4 Rotate the jaw chuck components until you hear a click.

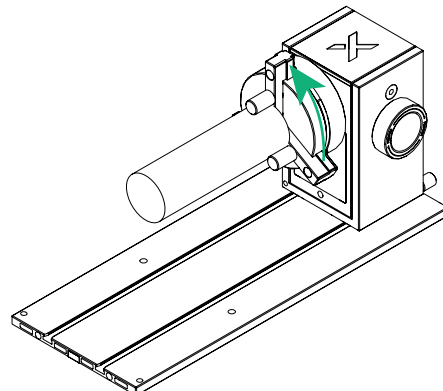

5 Slide the support module into the main baseplate.

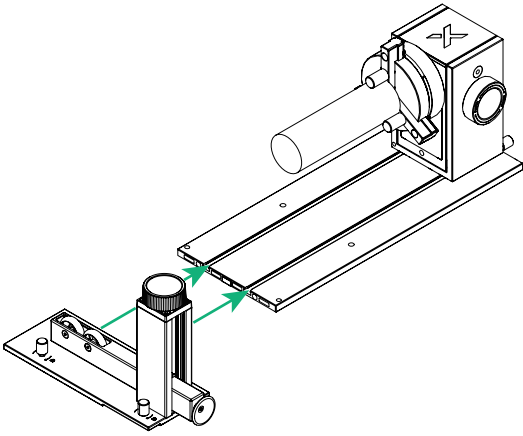

6 Rotate the knob clockwise to hold the support module in position.

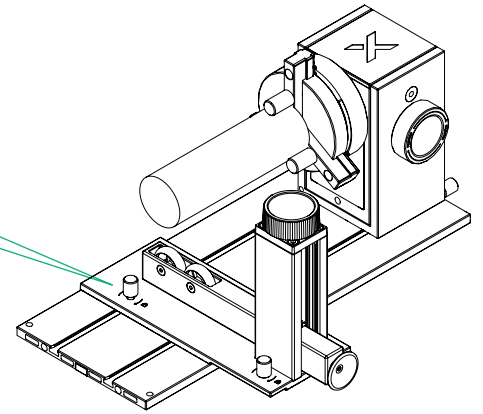
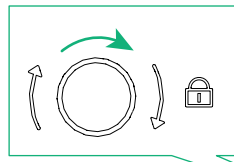

7 Rotate the knob to adjust the height of the two wheels on the support module until they touch the workpiece.

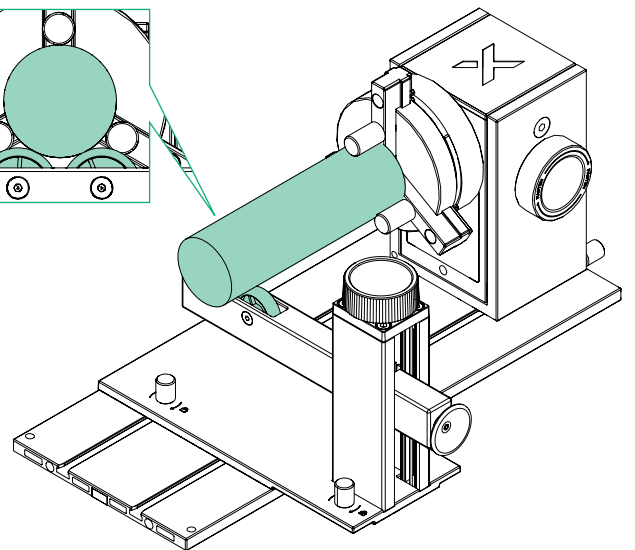
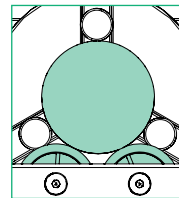
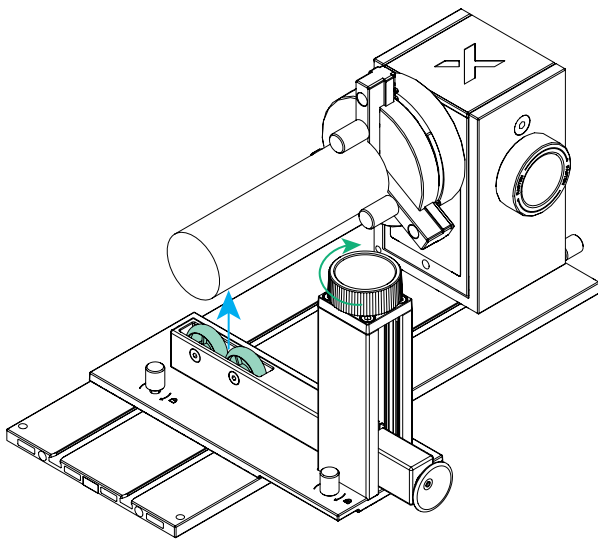

If the workpiece is long, there are two methods to use the support module.

■ Method 1:
Slide the support module into the main baseplate and hold it in position

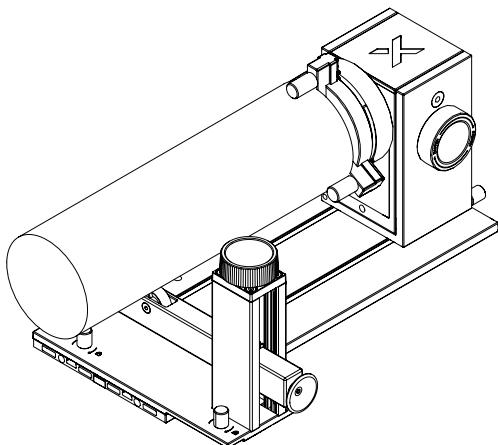

■ Method 2:
Place the support module outside the main baseplate

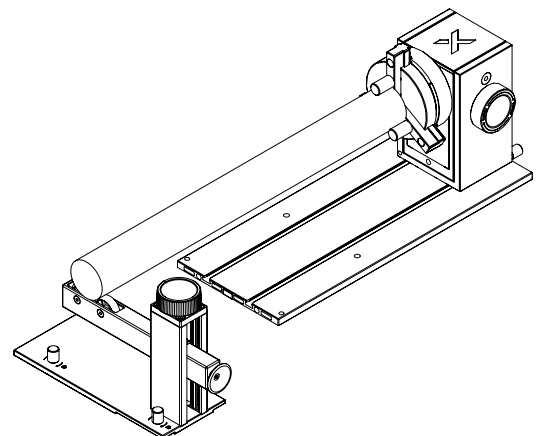



The following are common application scenarios for using extended jaws, as well as simultaneously using cylindrical jaws and T-shaped jaws.

(1) Extended jaws: Primarily suitable for processing rotating workpieces with a diameter of less than 80 mm. It is recommended to mount the extended jaws in the middle or the innermost holes of the jaw chuck.

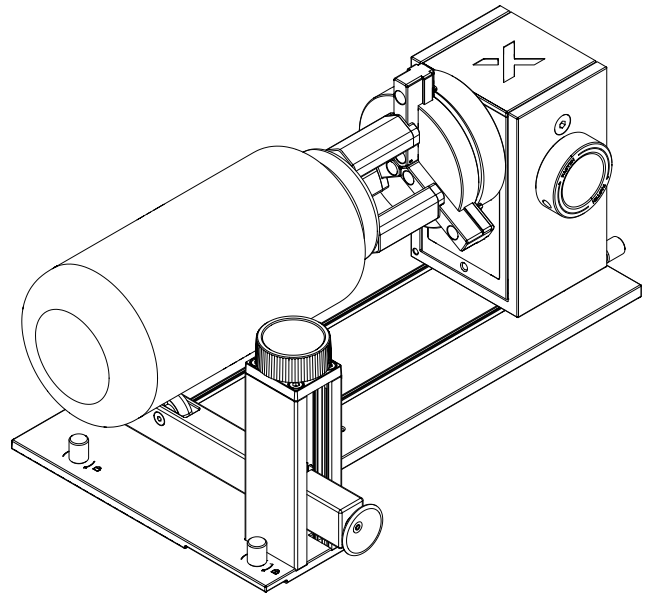
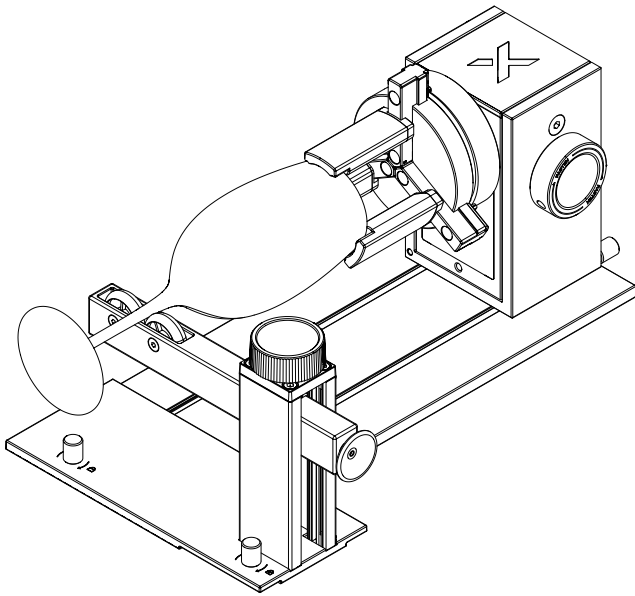

If other jaws are mounted in the middle or the innermost holes of the jaw chuck, there is a possibility that the laser module may collide with the jaw chuck or other components during processing.

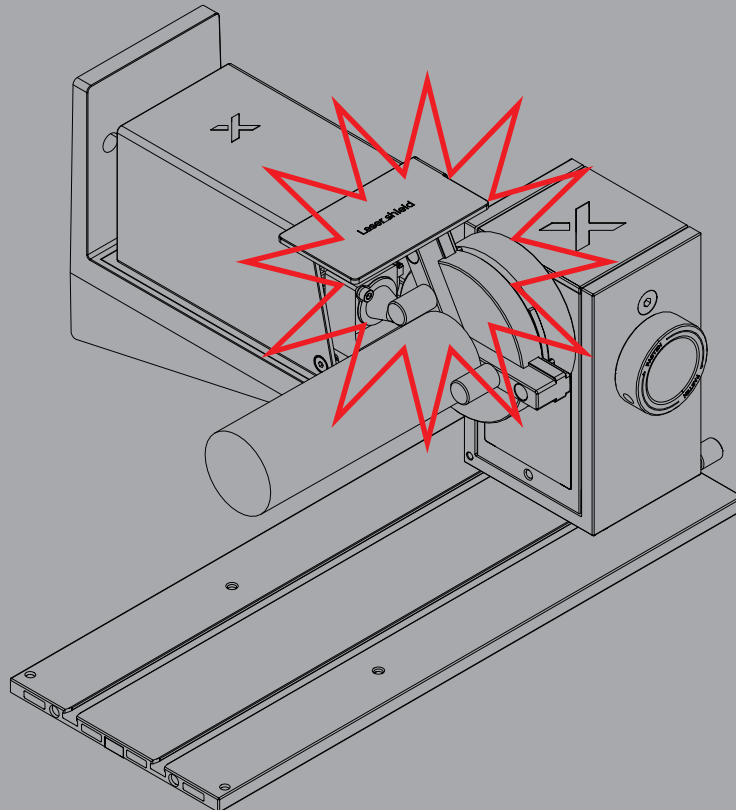

(2) Cylindrical jaws + T-shaped jaws: It is recommended to mount them in the outermost holes of the jaw chuck.

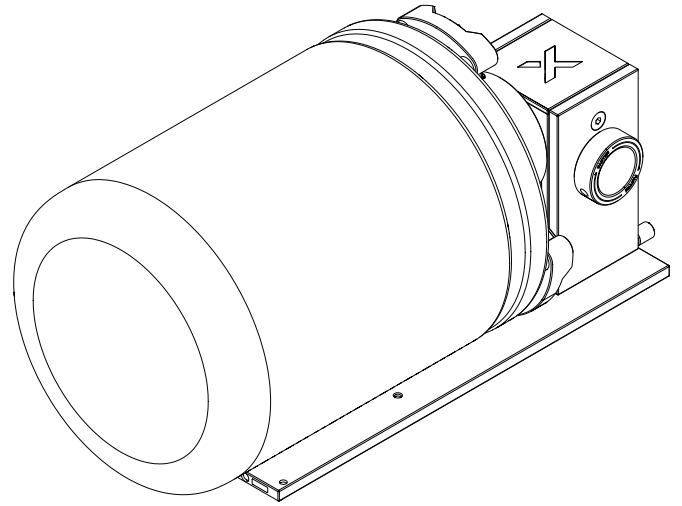
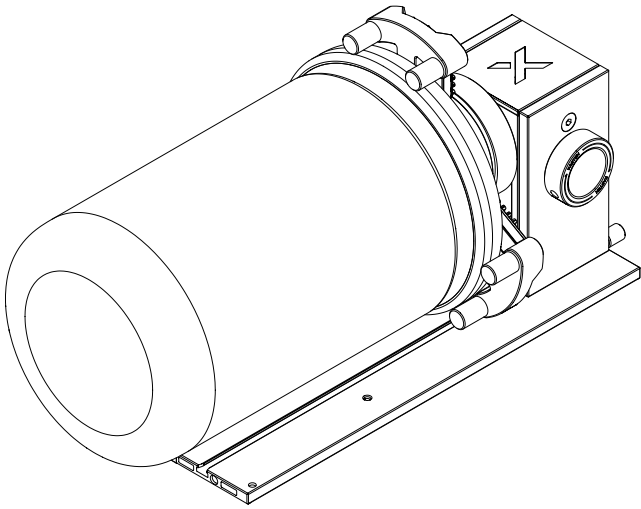

Process spherical objects

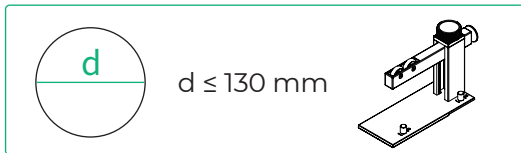

1 Insert the assembled jaw chuck components into the power module.

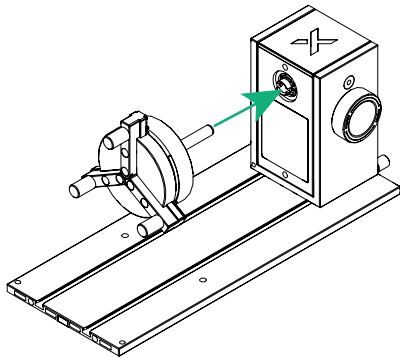

2 Rotate the jaw chuck components until you hear a click.

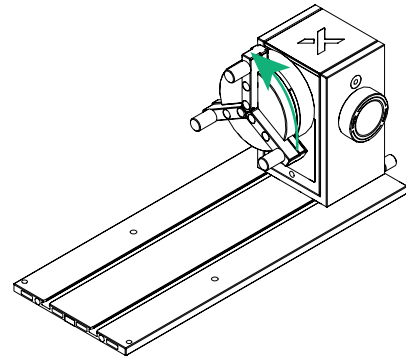

3 Place one side of the workpiece against the jaws.

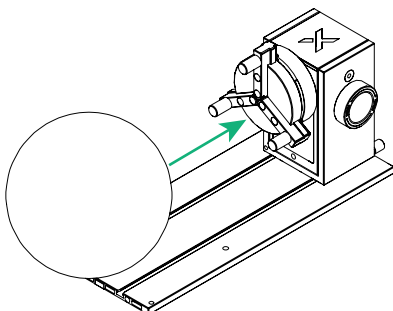

4 Slide the support module into the main baseplate, with its bell mouth against the other side of the workpiece.

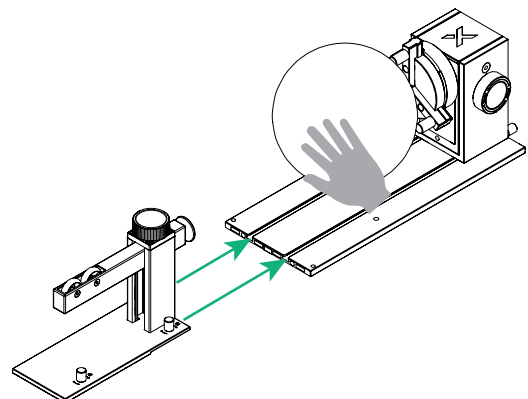

5 Rotate the knob clockwise to hold the support module in position.

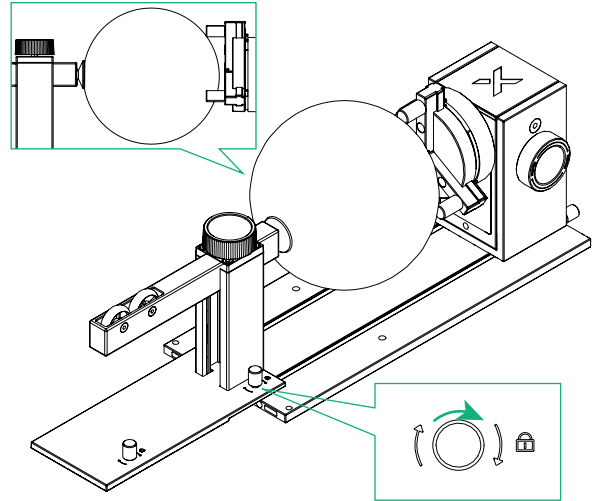

Process rings

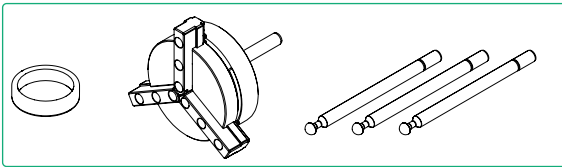

1 Install the stud components.

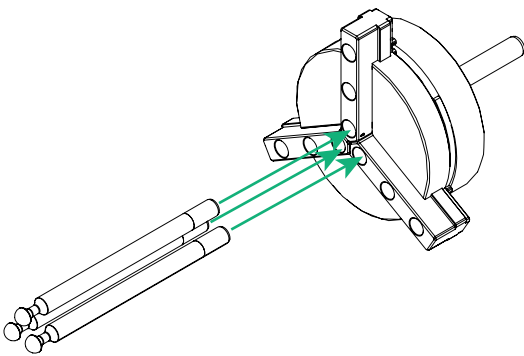

2 Place the ring onto the stud components.

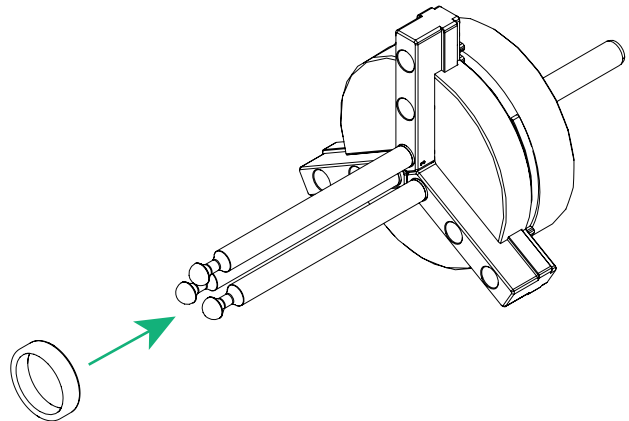

3 Rotate the knob to secure the ring.

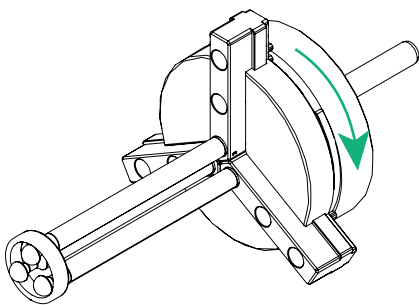

4 Insert the jaw chuck into the power module.

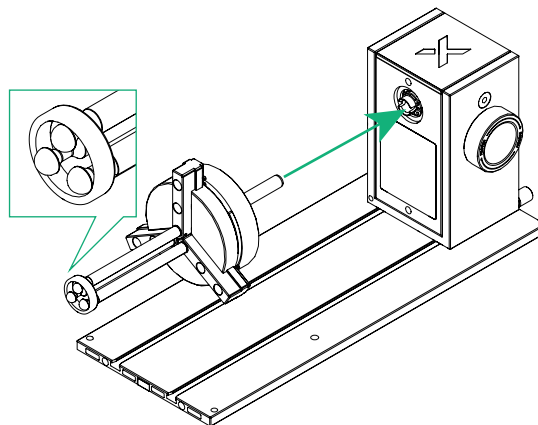

- 5** Rotate the jaw chuck until you hear a click.

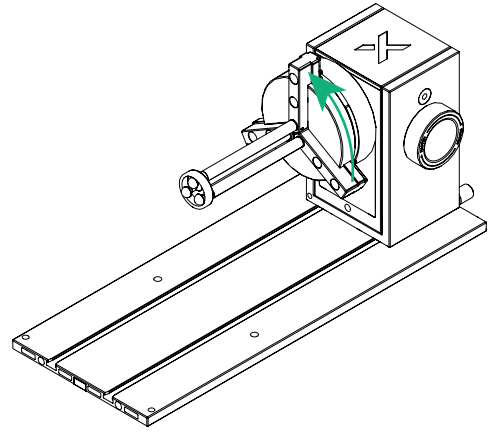

Use with xTool M2

- 1** Press the power switch of xTool M2 to turn off the device.

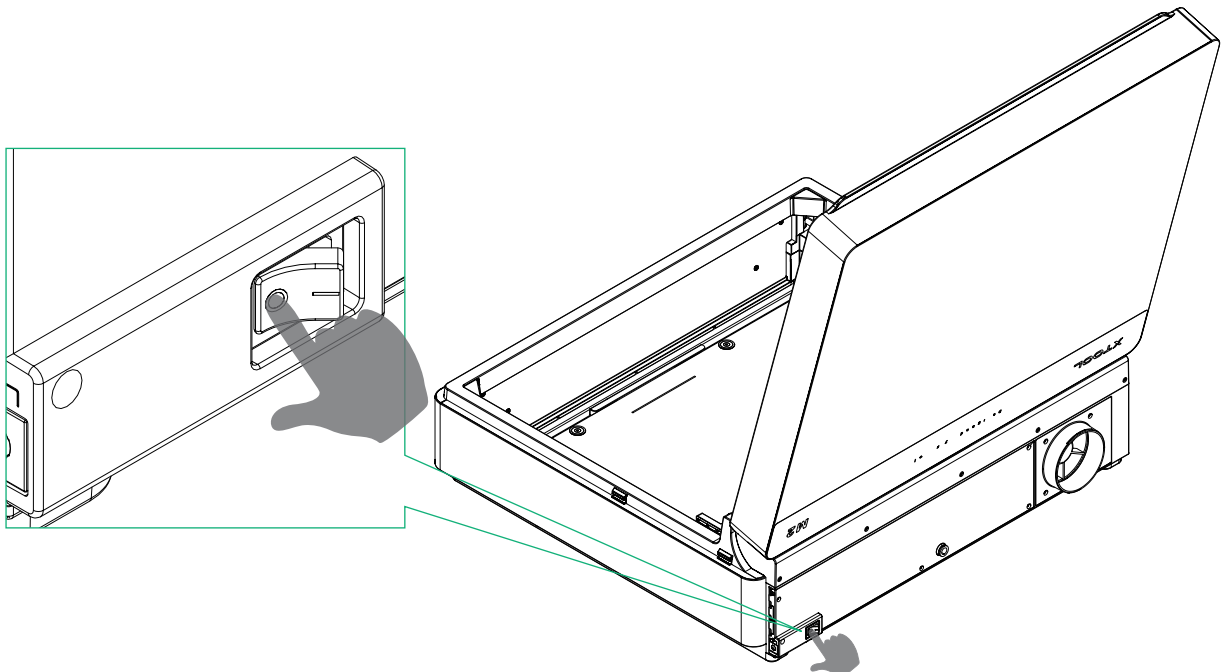
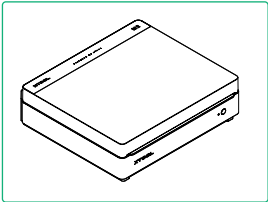

2 Remove the module connection cable.

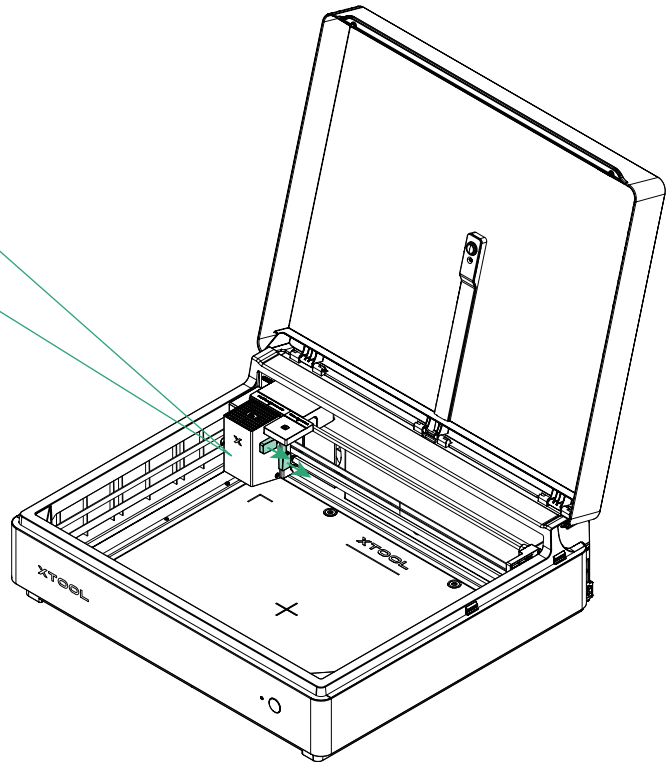

3 Remove the laser module.

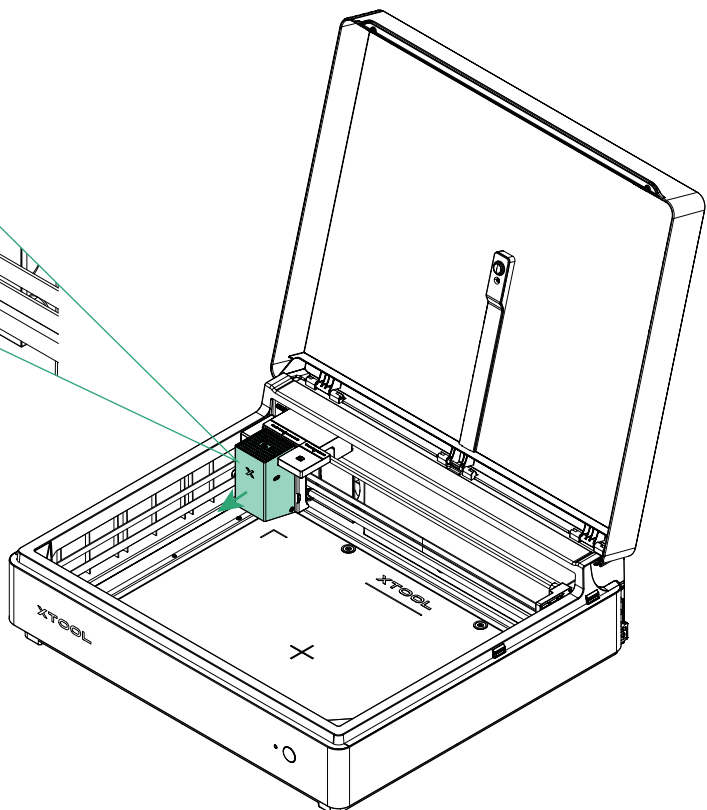
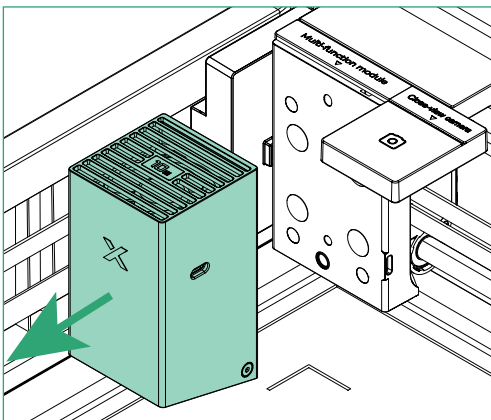

4 Attach the horizontal laser emission holder to the multi-function module holder.

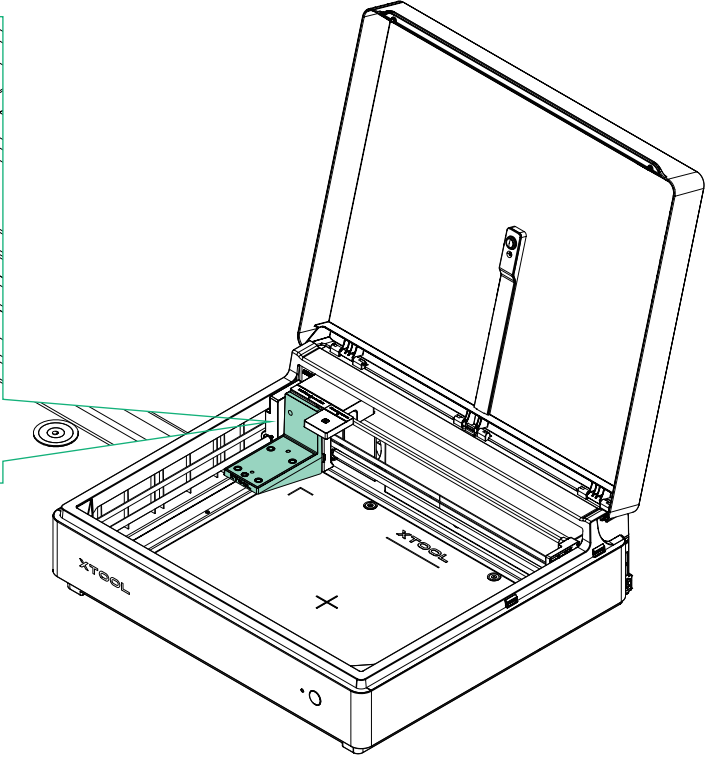
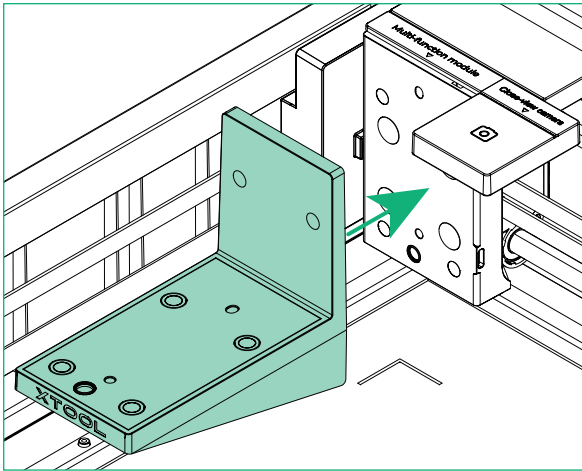
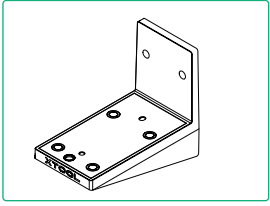

5 Install the laser shield to the laser module.

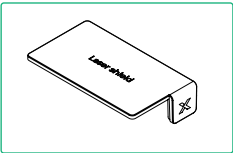

For the 10 W, 20 W, or 40 W laser module, install the laser shield as illustrated. For the 3 W laser module, installation of the laser shield is not necessary.

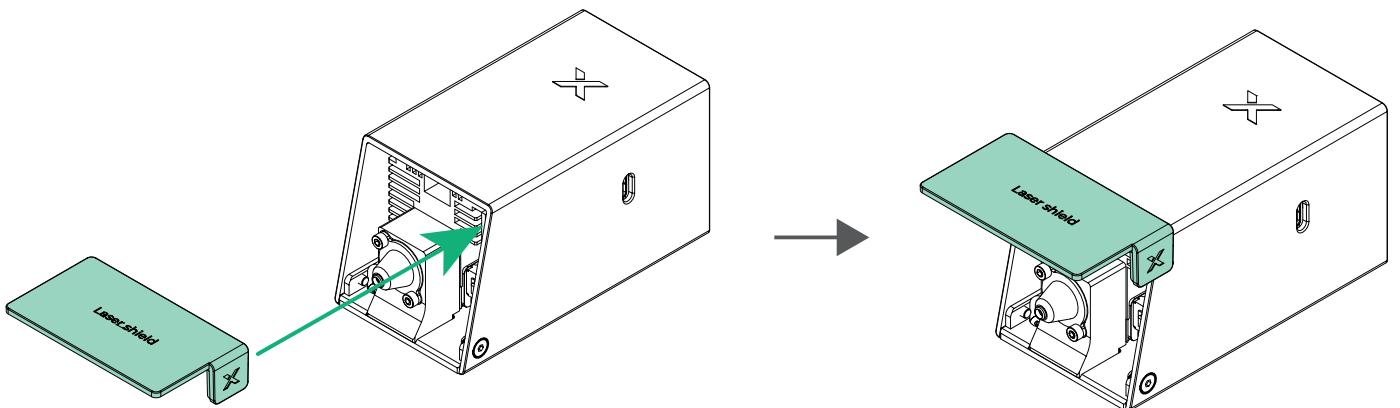

6 Attach the laser module to the horizontal laser emission holder.

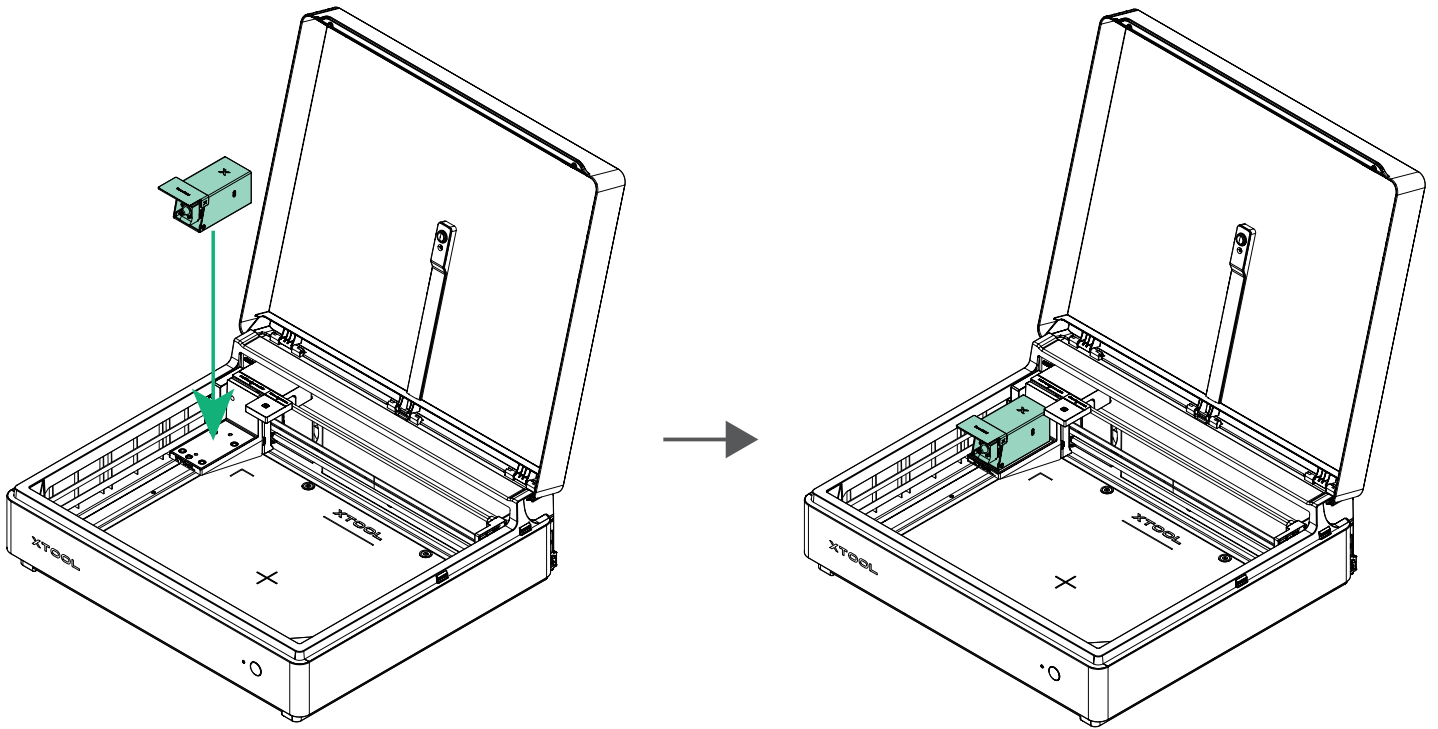

7 Connect the laser module to the device using the module connection cable.

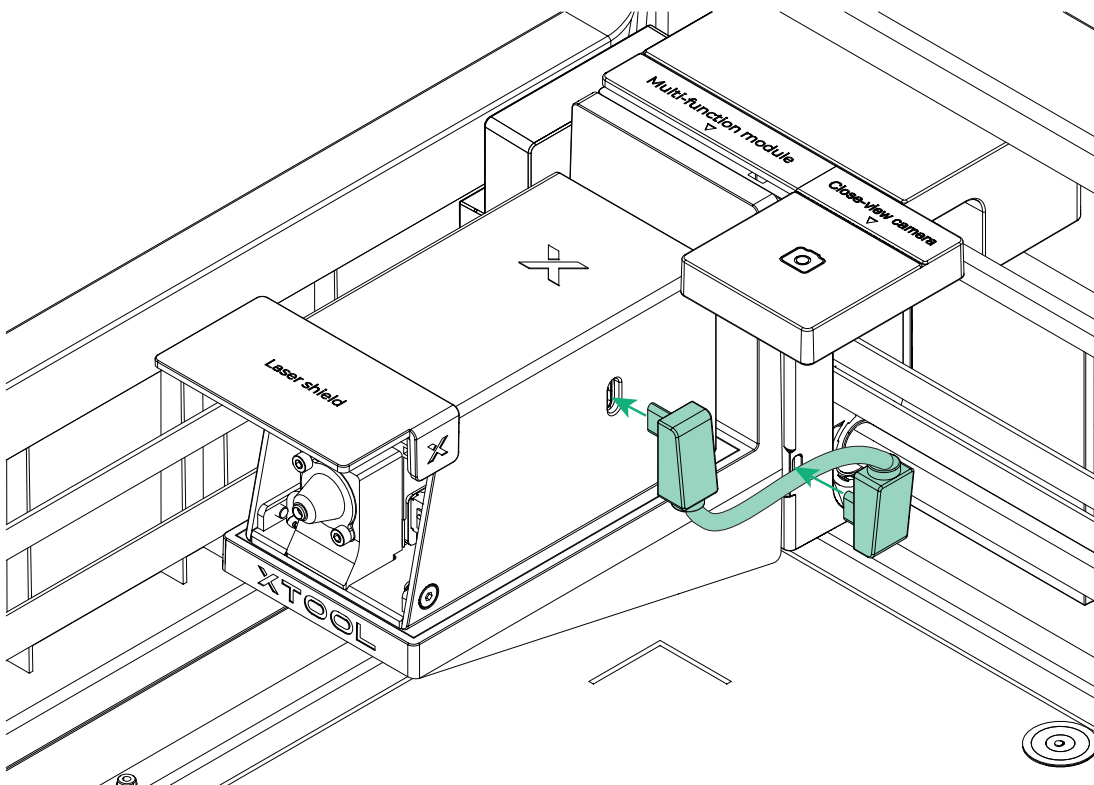

8 Position the assembled power module and main baseplate close to the center of the device.

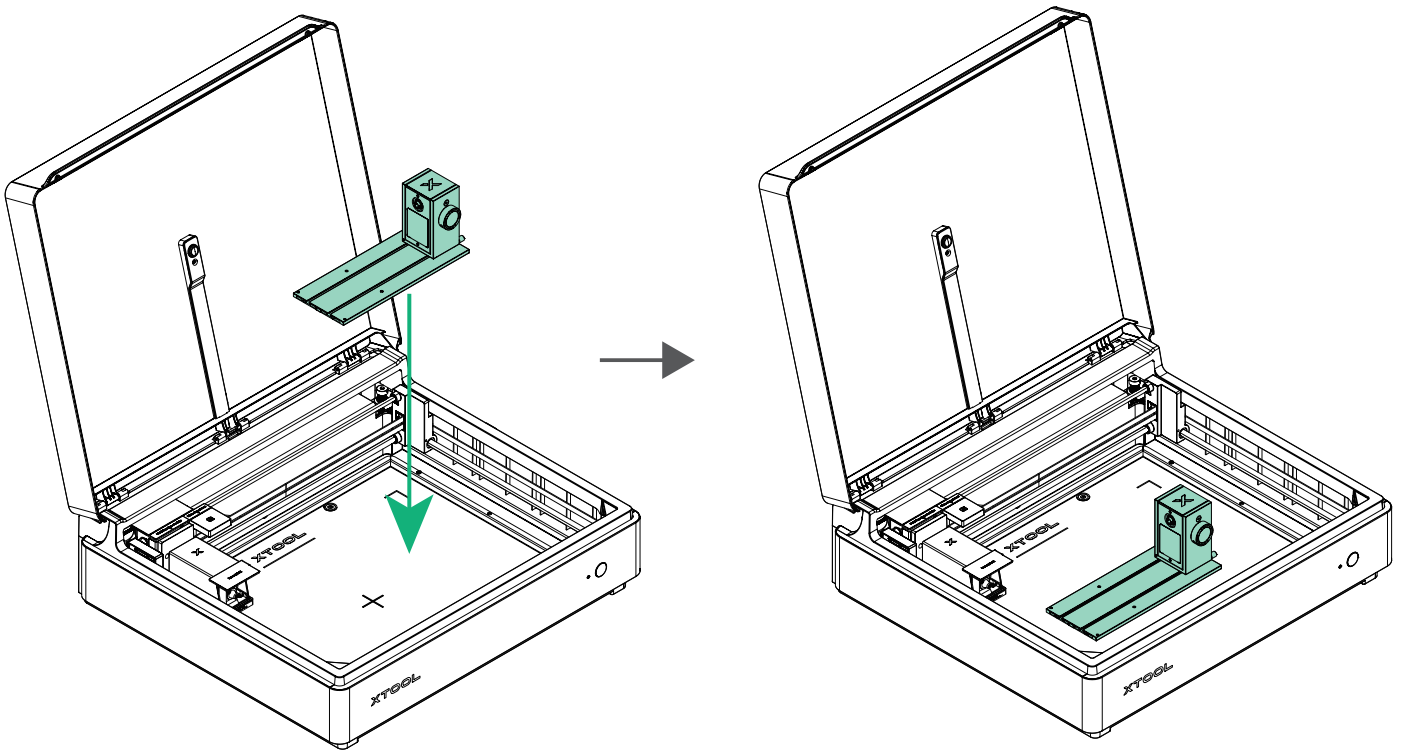

9 Insert one end of the device connection cable into the port on the back of the power module.

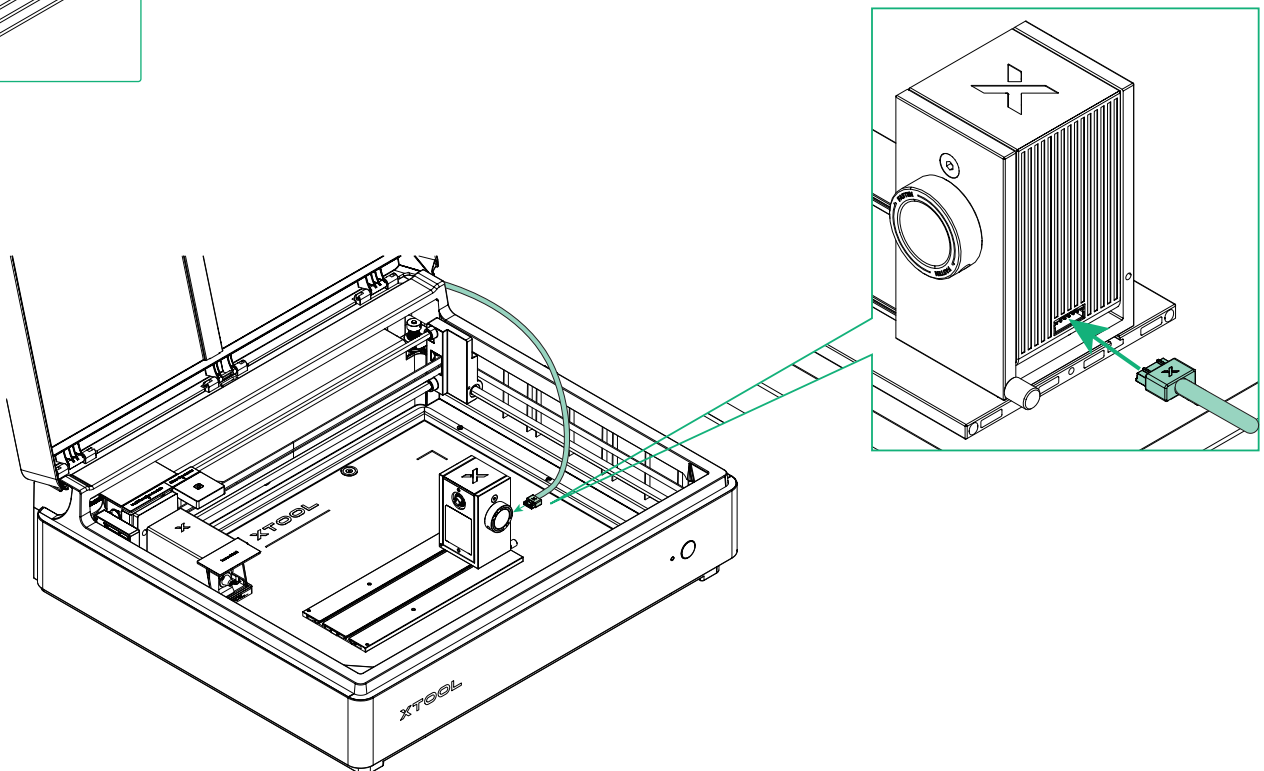
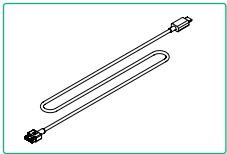

10 Place the positioning plate in the bottom-right corner inside the device.

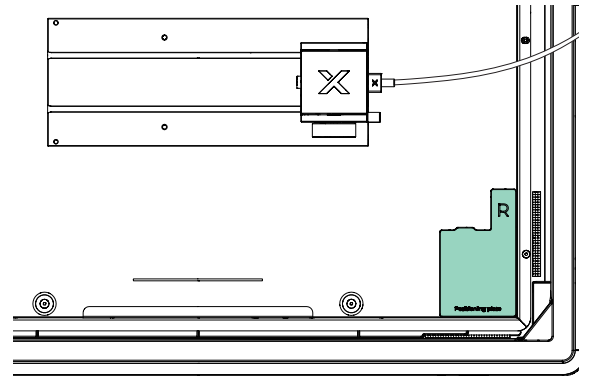
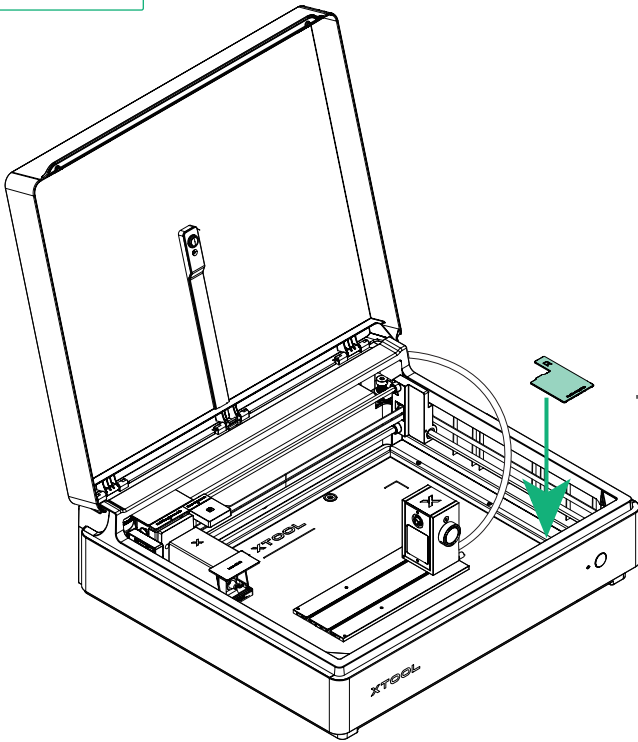
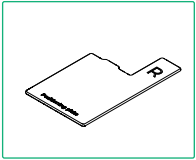

11 Move xTool Rotary Attachment 3 Lite next to the positioning plate, ensuring it is placed securely against the plate.

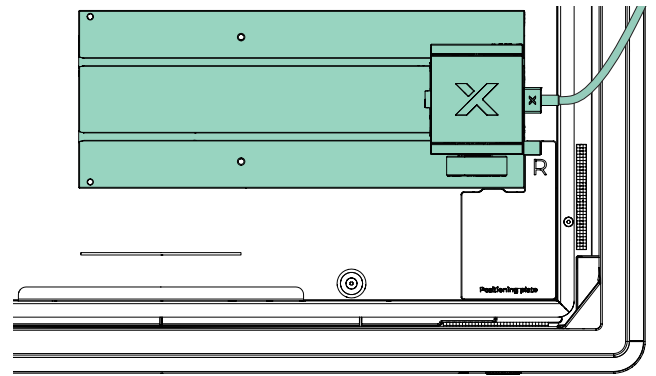
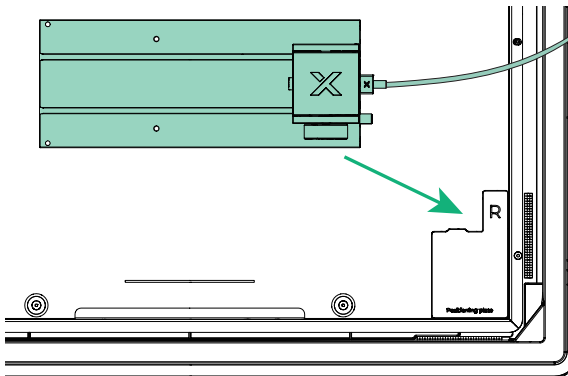

12 Place the other positioning plate on the other side of the main baseplate.

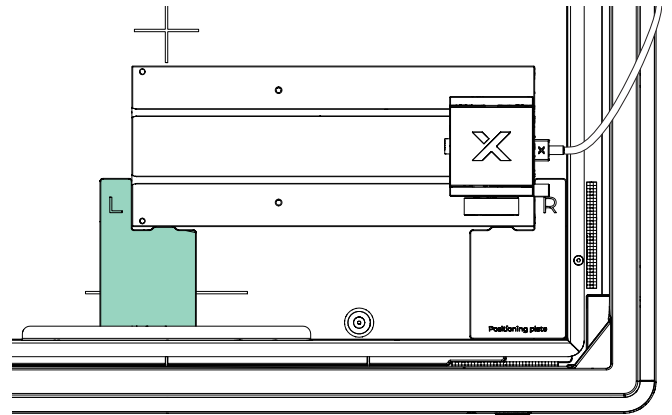
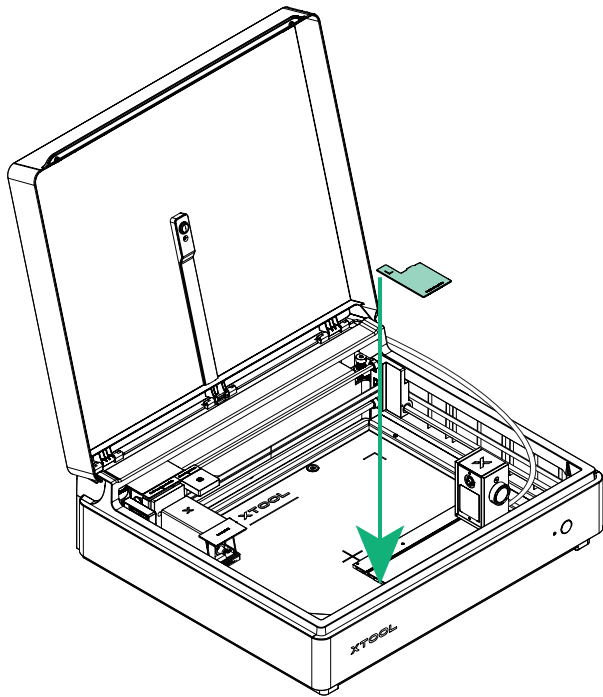
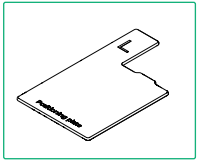

13 Install the workpiece onto xTool Rotary Attachment 3 Lite.

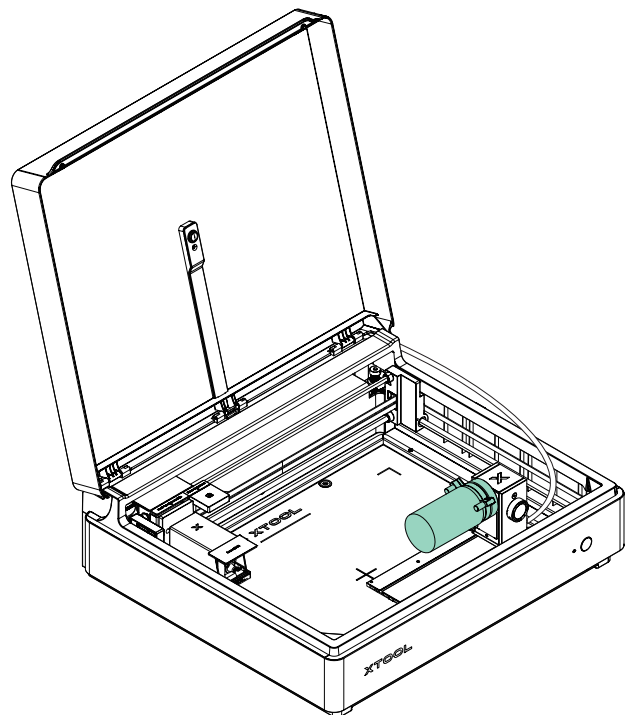
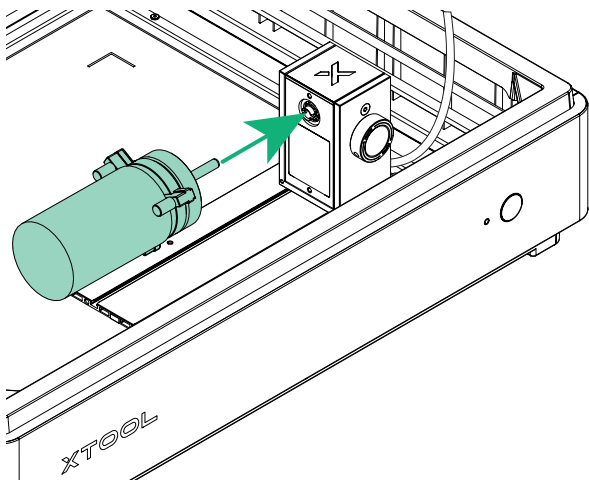

- 14 Secure the device connection cable to the cable clamps, and insert the other end into any extension port on the device.

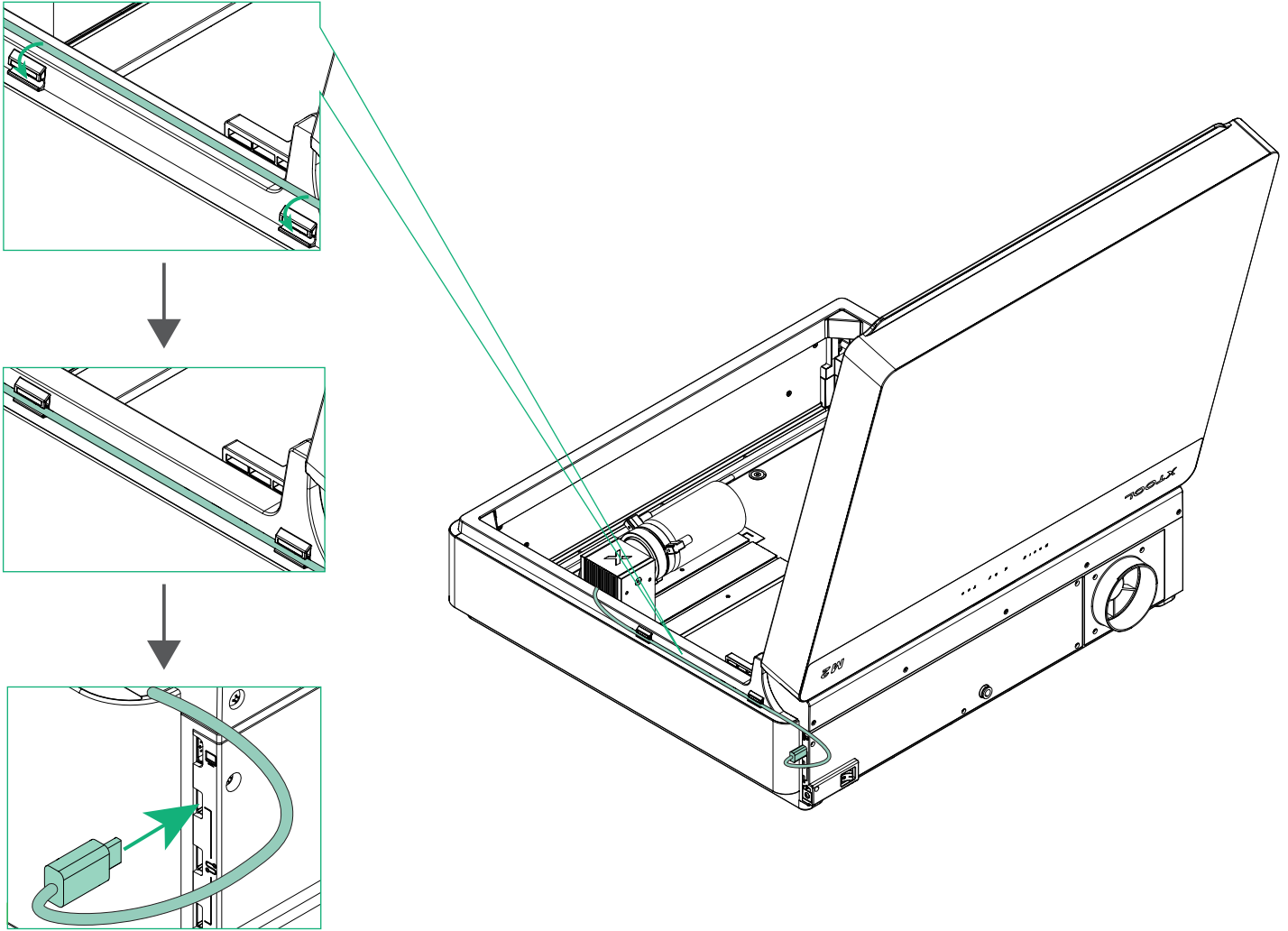

If you have not removed the sticker from xTool M2 extension ports, remove it first, then insert the other end of the device connection cable into any extension port.

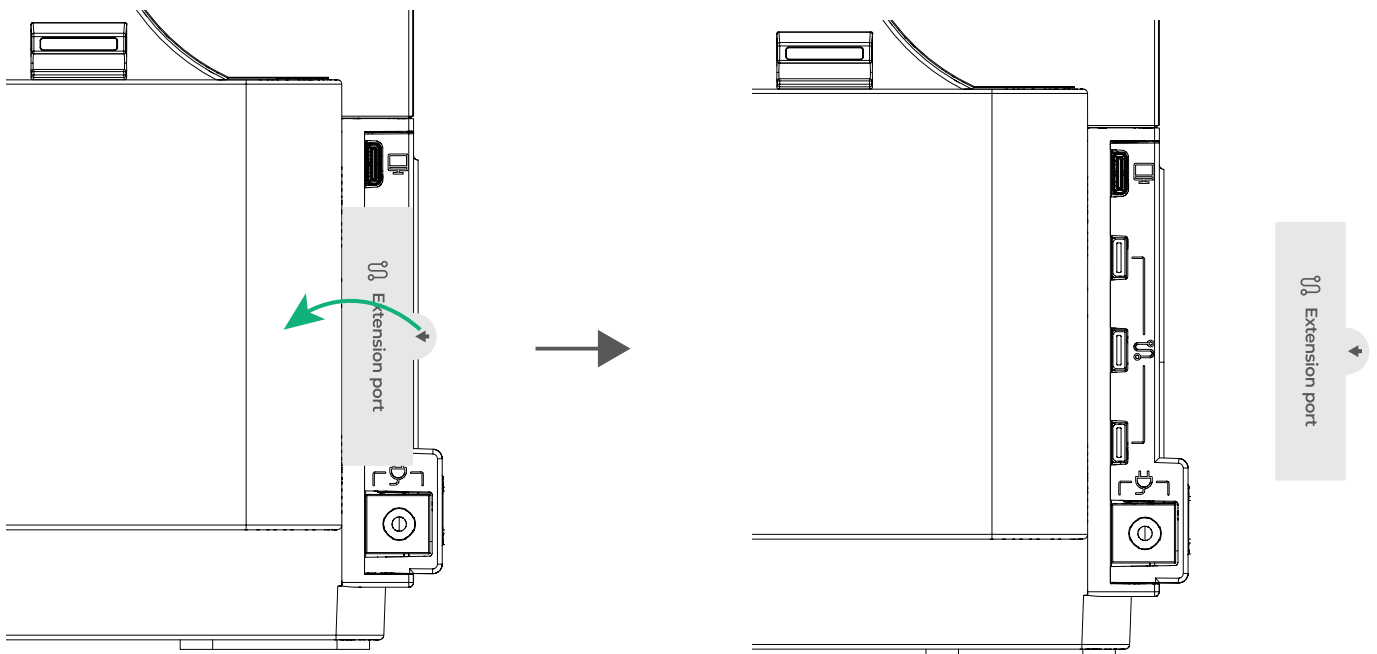

15 Close the lid.

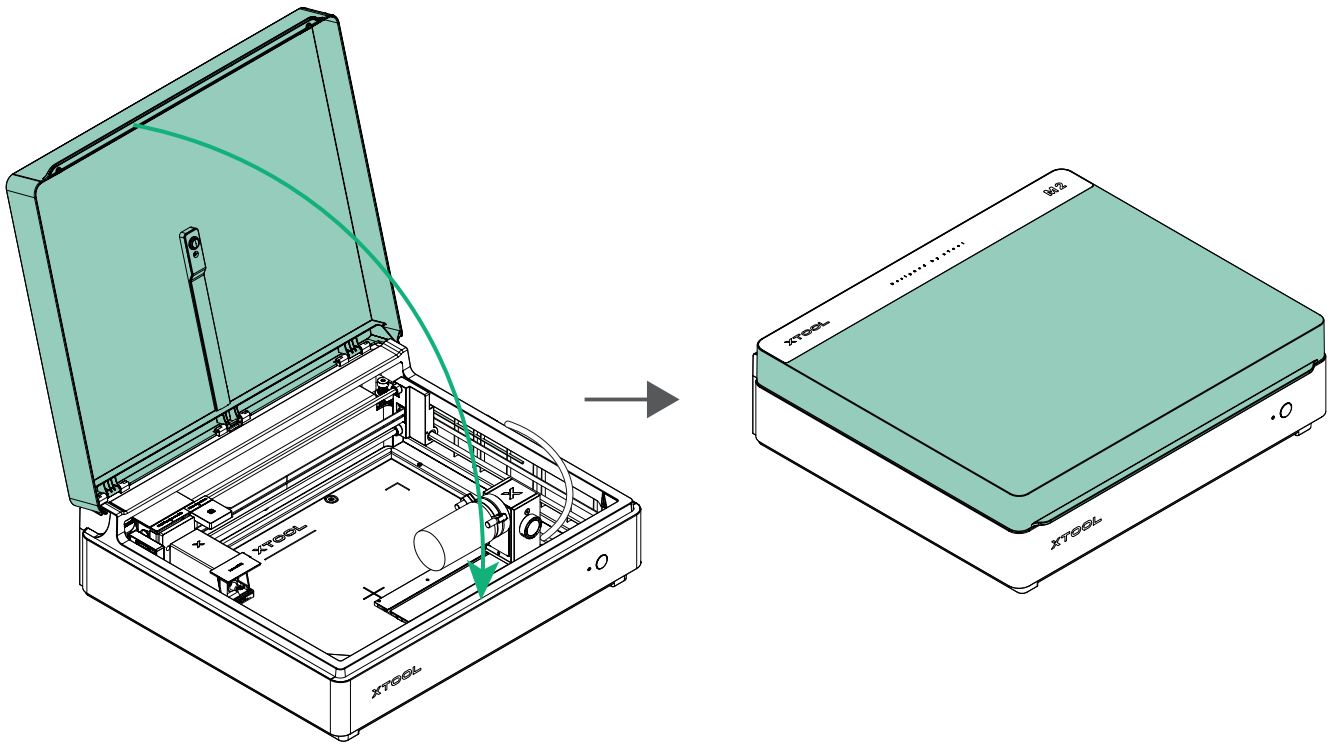

After closing the lid, always check whether the device connection cable is correctly led through the notch in the lid. If it is not positioned properly, open the lid and adjust the cable to ensure it is not squeezed.

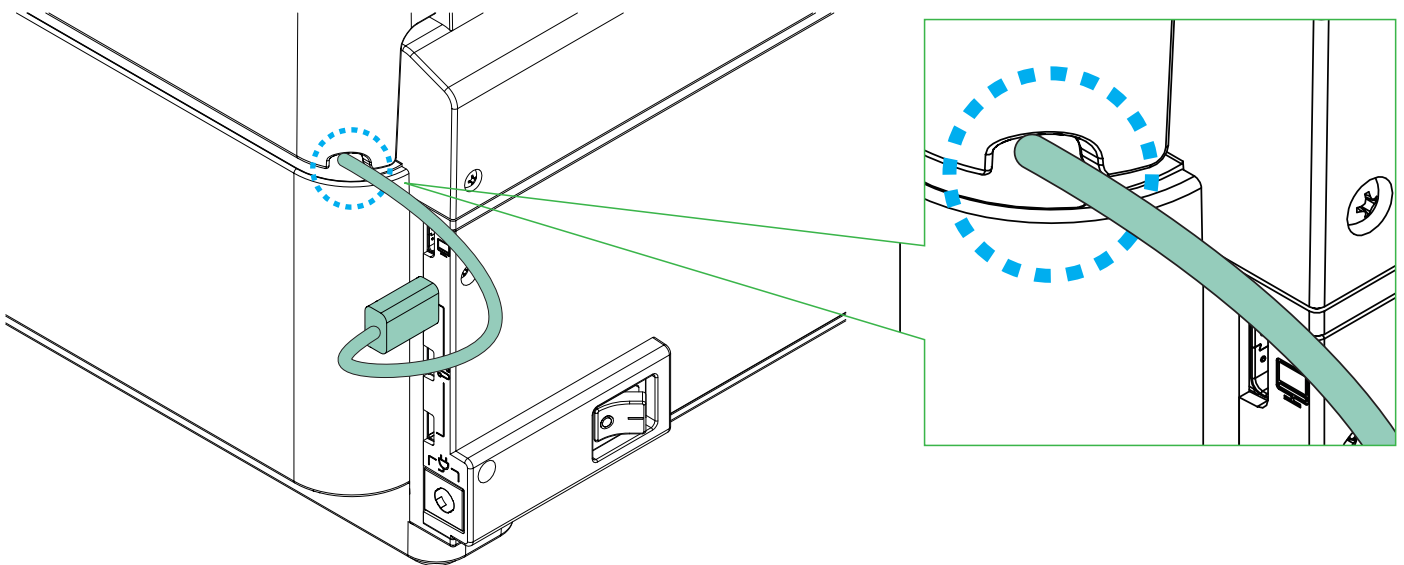

16 Open the xTool software and follow the instructions to complete the subsequent steps. Visit the link or scan the QR code for details.



support.xtool.com/article/2920

*Some language versions are translated by artificial intelligence (AI). If there are any inaccuracies or ambiguities, please contact us promptly. We will verify and optimize the content as soon as possible.

XTOOL