

MAKE X

V1.0_K0301000469

MAKE X

Inspire



Code Courier Arena Assembly Instructions

密码邮差场地搭建步骤图







List of Items 物料清单

01

Parts and Quantities\零件及数量	Index\编号	Parts and Quantities\零件及数量	Index\编号	Parts and Quantities\零件及数量	Index\编号
1× Red stepped cylinder 红色阶梯圆柱 	P01	1× Green stepped cylinder 绿色阶梯圆柱 	P02	1× Blue stepped cylinder 蓝色阶梯圆柱 	P03
1× Yellow stepped cylinder 黄色阶梯圆柱 	P04	1× MakeX blue ball MakeX 蓝色球 	P05	1× MakeX red ball MakeX 红色球 	P06
1× MakeX yellow ball MakeX 黄色球 	P07	1× MakeX green ball MakeX 绿色球 	P08	5× Red ring 红色圆环 	P09
5× Blue ring 蓝色圆环 	P10	5× Yellow ring 黄色圆环 	P11	5× Green ring 绿色圆环 	P12
1× Yellow cube 黄色方块 	P13	1× Red cube 红色方块 	P14	1× Blue cube 蓝色方块 	P15

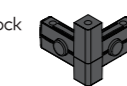
List of Items 物料清单

02

Parts and Quantities\零件及数量	Index\编号	Parts and Quantities\零件及数量	Index\编号	Parts and Quantities\零件及数量	Index\编号
1x Green cube 绿色方块	 P16	4x L-shaped beam lock L型卡锁	 P17	4x I-shaped beam lock I型卡锁	 P18
8x Side beam 边条	 P19	1x Map 地图	 P20	1x Fabric tape 布基胶带	 P21

Some parts are spare ones. Keep them properly.
部分物料有冗余, 请妥善保管。

Frame Assembly 边框搭建

03

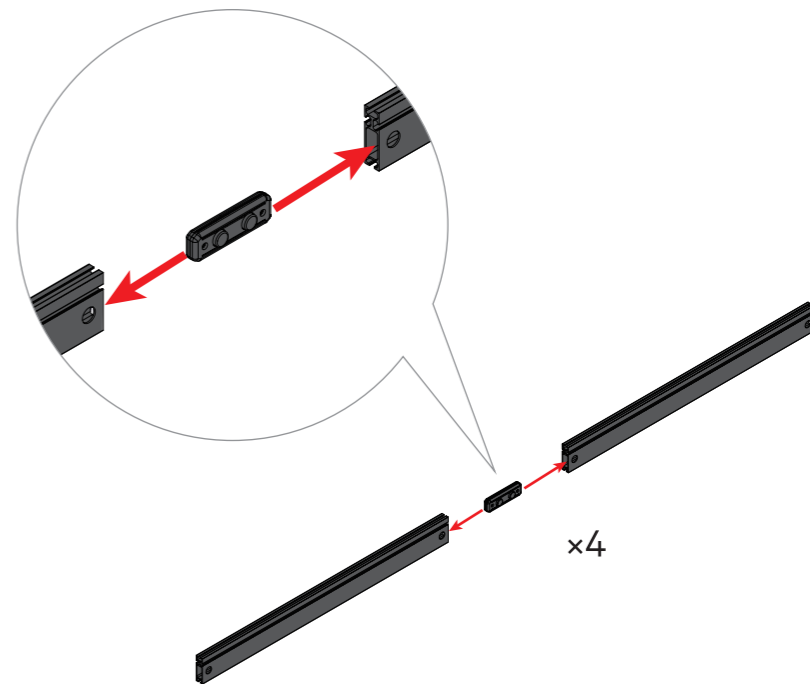

Frame Assembly 边框搭建

04

4x



P17

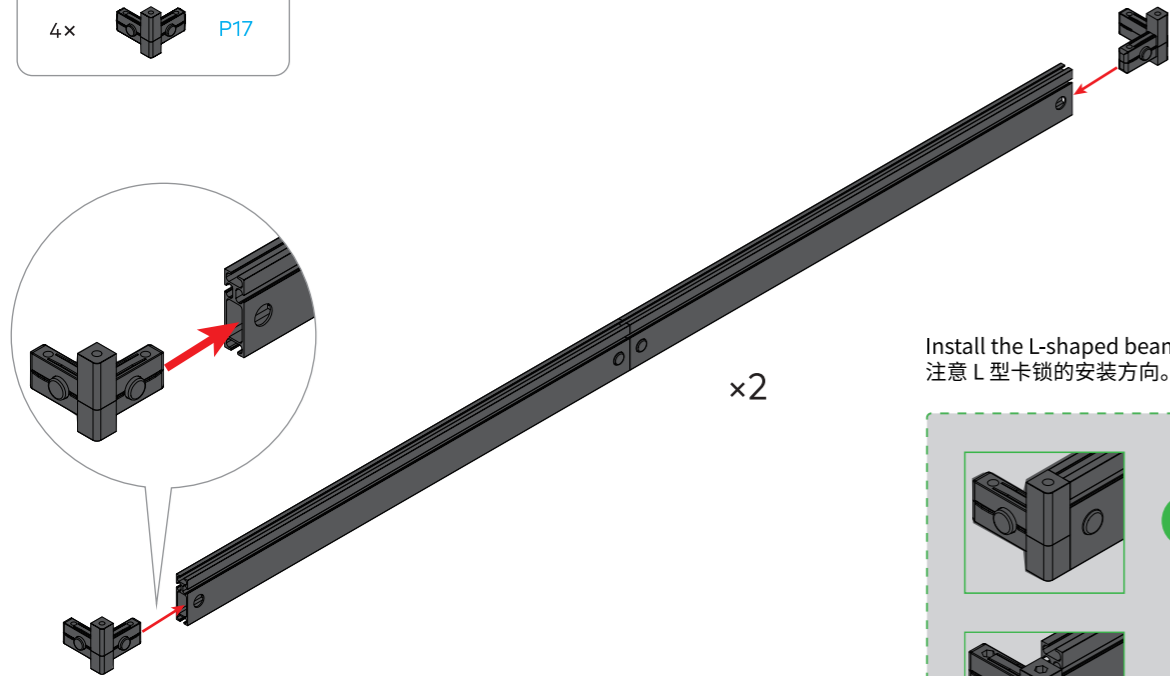

x2

Install the L-shaped beam locks in the correct orientation.
注意 L 型卡锁的安装方向。

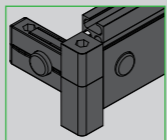
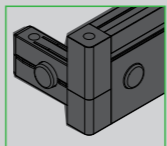

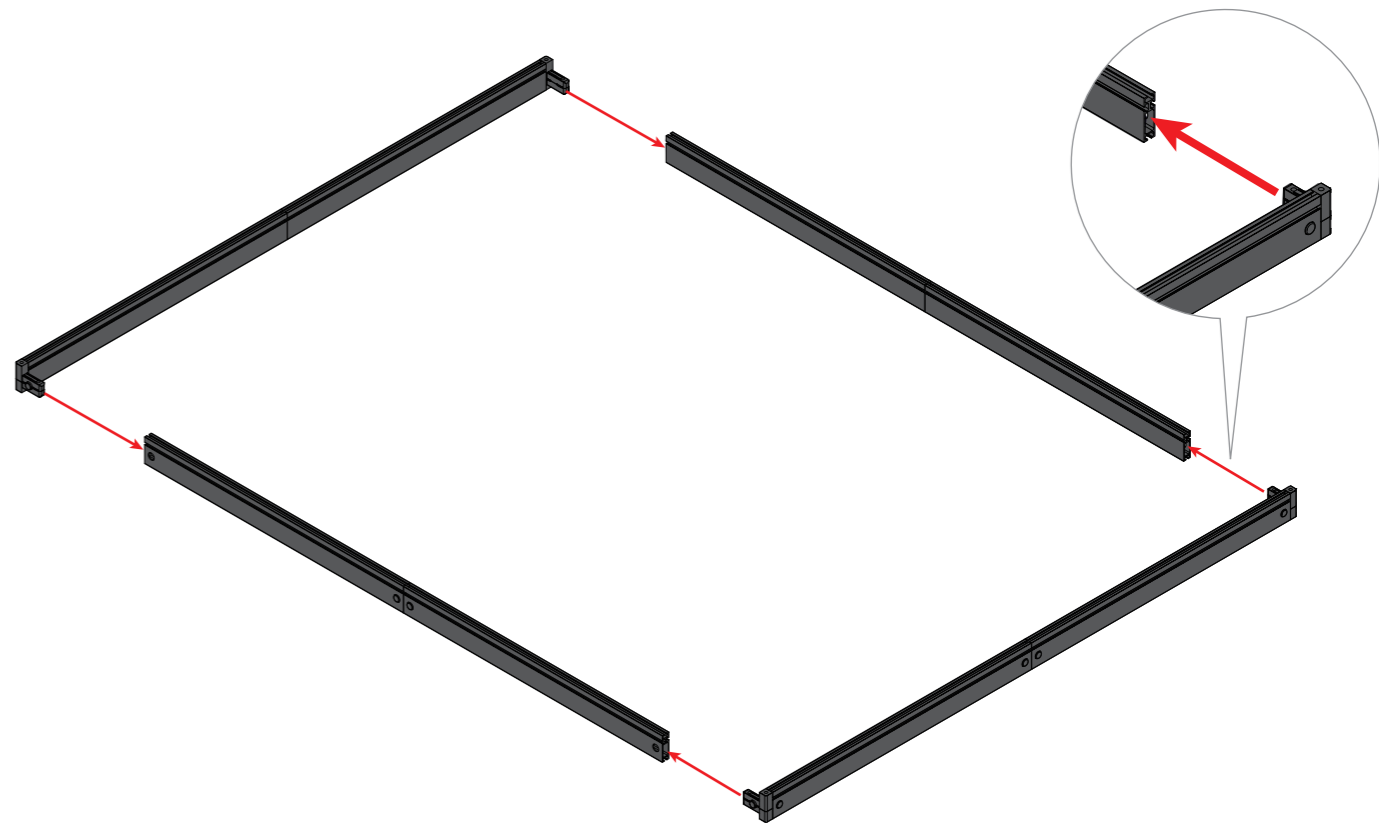

Frame Assembly 边框搭建

05

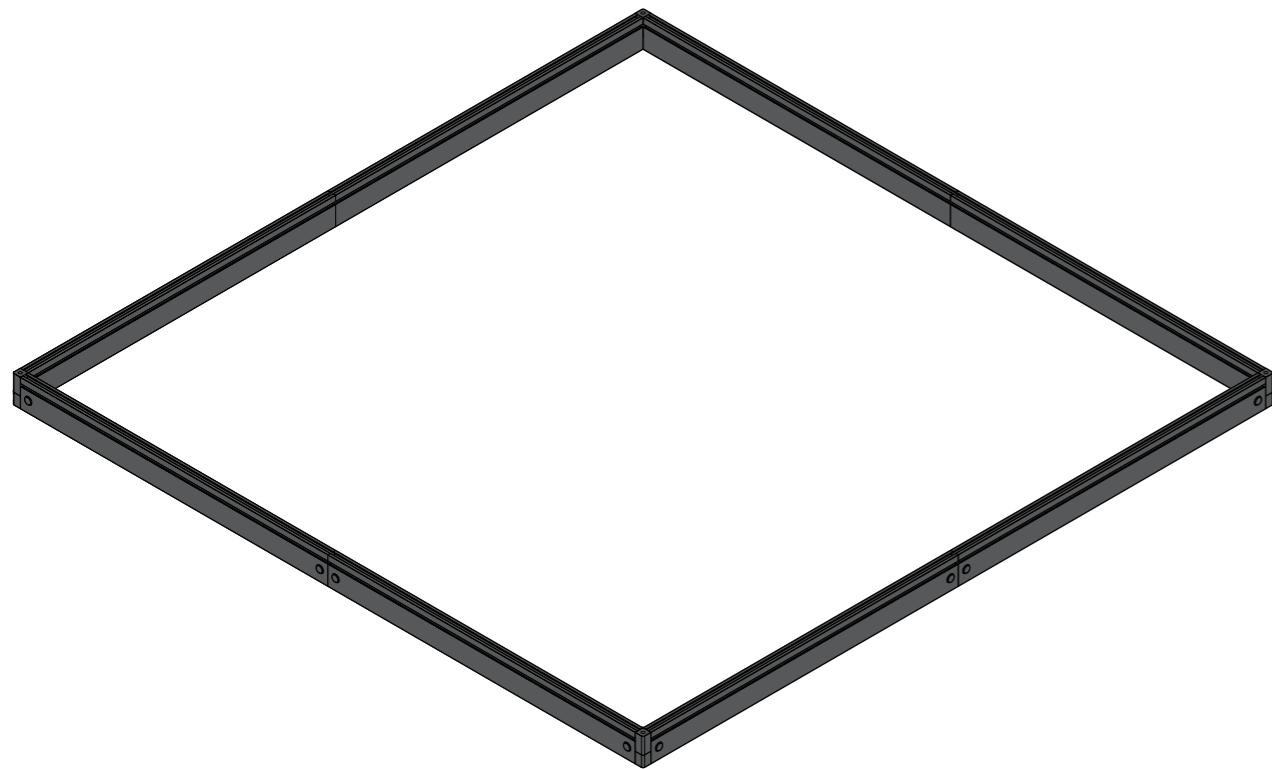



- 1x  P20
- 1x  P21

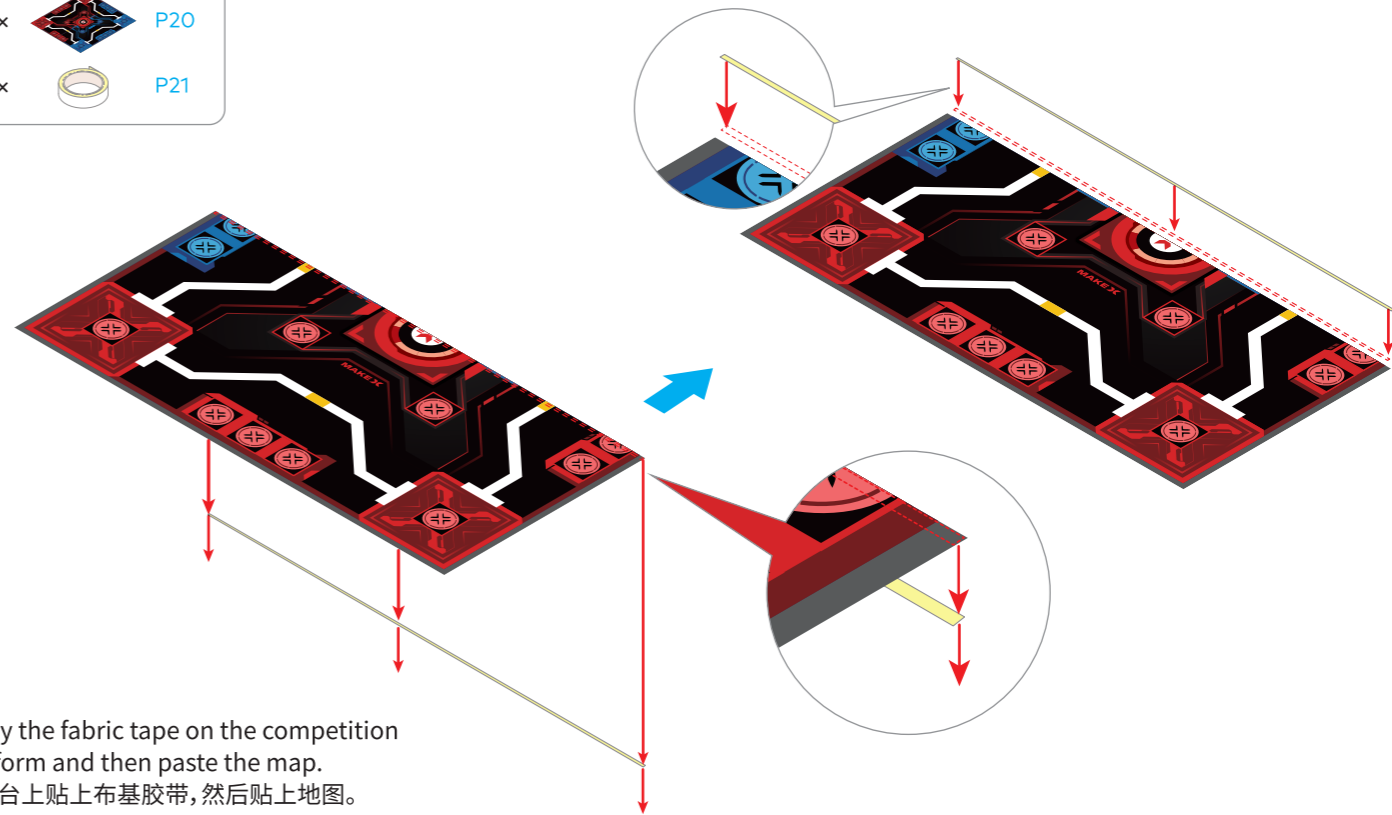

Apply the fabric tape on the competition platform and then paste the map.
在赛台上贴上布基胶带, 然后贴上地图。

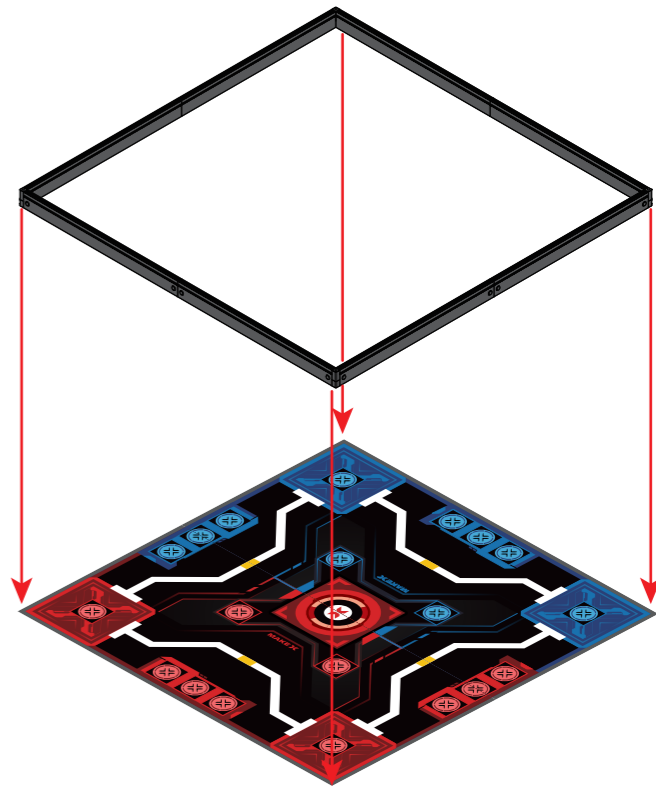
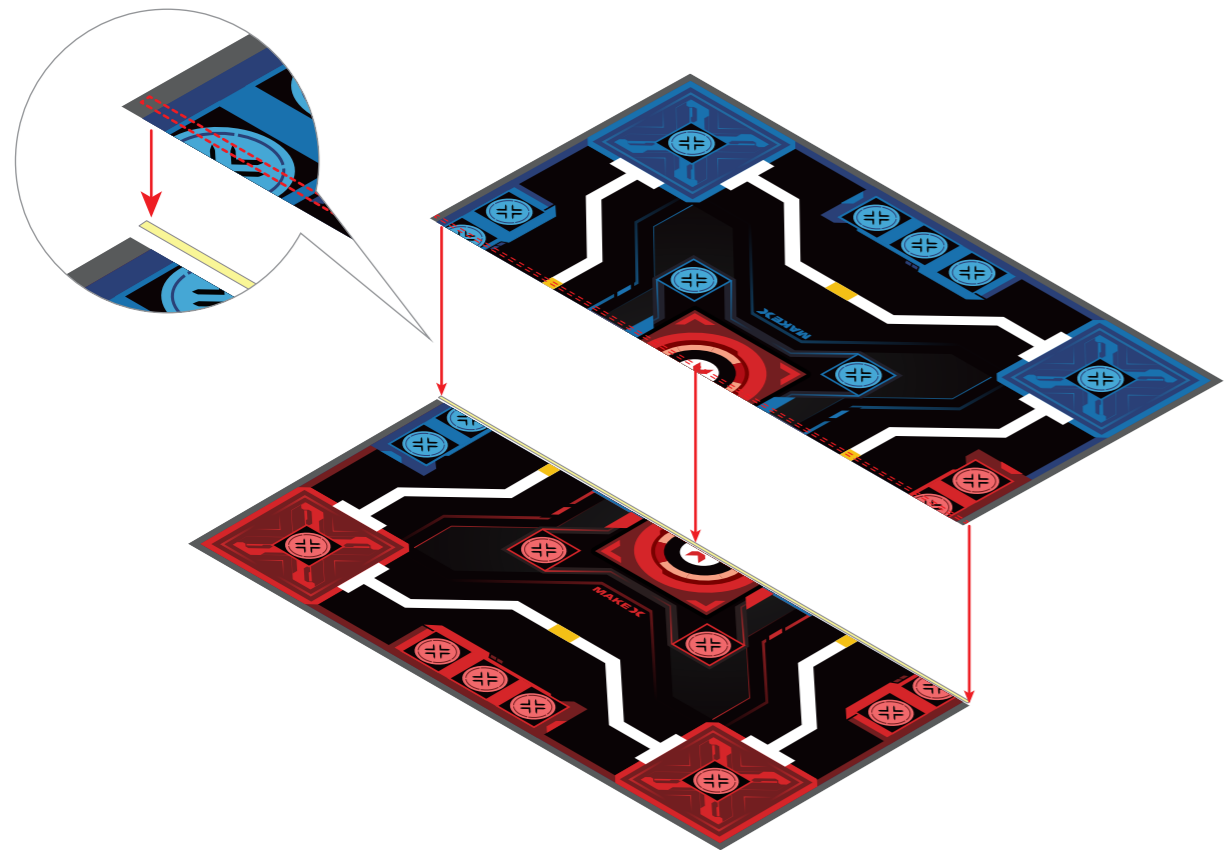

Depending on the actual arena requirements, you may choose to use fabric tape to secure the frame to the map surface.
可根据实际场地使用需求, 选择是否使用布基胶带将边框固定于地图表面。



The placement of the parts is for reference only. Find details in the mission description.
道具摆放位置可参考下图, 具体以比赛任务说明为准。

