

# MAKE X

## Explorer

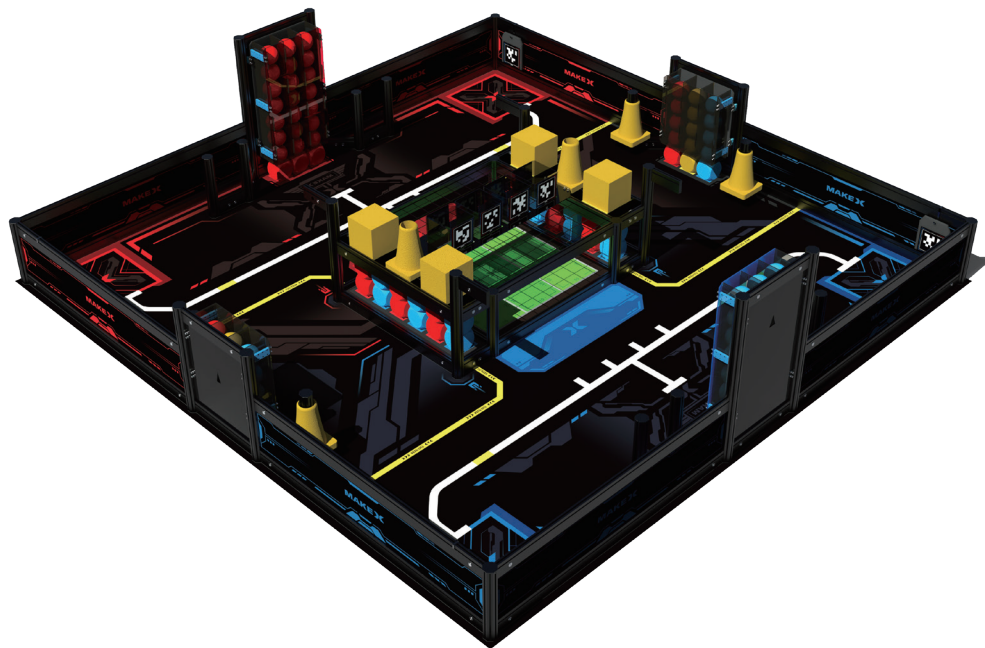







Strategy Front Arena Assembly Instructions  
博弈前线场地搭建步骤图

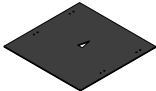
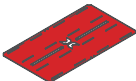

# Parts List 零件清单 - General Pack 标准场地包

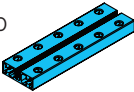
01

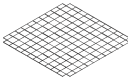
Parts and Quantities\零件及数量	Index\编号	Parts and Quantities\零件及数量	Index\编号	Parts and Quantities\零件及数量	Index\编号
24 × Flat beam 1550-120 扁铝 1550-120 	P01	116 × Flat beam lock 三卡锁 	P06	4 × MakeX board A1 A1 红黑护栏板 	P11
8 × Flat beam 1550-293 扁铝 1550-293 	P02	20 × Octagonal pillar 4040-250 八棱柱 4040-250 	P07	4 × MakeX board A2 A2 蓝黑护栏板 	P12
12 × Flat beam 1550-560 扁铝 1550-560 	P03	8 × Octagonal pillar 4040-400 八棱柱 4040-400 	P08	1 × Board B1 B1 板 	P13
16 × Flat beam 1550-960 扁铝 1550-960 	P04	4 × Octagonal pillar 4040-600 八棱柱 4040-600 	P09	4 × Board B2 B2 板 	P14
4 × Flat beam cover 扁铝封盖 	P05	64 × Octagonal pillar cover 八棱柱封盖 	P10	1 × Board C1 C1 板 	P15

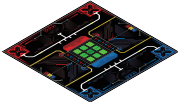

Parts and Quantities\零件及数量	Index\编号	Parts and Quantities\零件及数量	Index\编号	Parts and Quantities\零件及数量	Index\编号
2 × Board D1 D1板 	P16	2 × Board I1 I1板 	P21	165 × Screw M4*8 螺丝 M4*8 	P26
1 × Board E1 E1板 	P17	2 × Board J1 J1板 	P22	20 × Slide beam O16 滑轨双孔梁 O16 	P27
1 × Board F1 F1板 	P18	8 × Board J2 J2板 	P23	20 × Slide beam O80 滑轨双孔梁 O80 	P28
8 × Board G1 G1板 	P19	2 × Board K1 K1板 	P24	1 × Square mesh 方形网 	P29
2 × Board H1 H1板 	P20	8 × Board L1 L1板 	P25	1 × Map 地图 	P30

# Parts List 零件清单 - General Pack 标准场地包

03

Parts and Quantities\零件及数量	Index\编号	Parts and Quantities\零件及数量	Index\编号	Parts and Quantities\零件及数量	Index\编号
28 x Blue ball 蓝色球 	P31	17 x Blue cube 70 mm 蓝色方块 70 mm 	P36	8 x Sticker 1 贴纸 1 	P41
28 x Red ball 红色球 	P32	4 x Yellow cube 120 mm 黄色方块 120 mm 	P37	1 x Sticker 2 贴纸 2 	P42
14 x Yellow ball 黄色球 	P33	4 x Transparent square box 透明方盒 	P38	1 x Hex Allen key T30 L型内六角梅花型 扳手 T30 	P43
3 x Yellow cube 70 mm 黄色方块 70 mm 	P34	6 x Yellow cone 黄色锥桶 	P39	1 x Screwdriver 3.0 mm 螺丝刀 3.0 mm 	P44
17 x Red cube 70 mm 红色方块 70 mm 	P35	4 x Hook 挂钩 	P40	1 x Double-sided fabric tape 双面布基胶带 	P45

# Parts List 零件清单 - General Pack 标准场地包



Parts and Quantities\零件及数量	Index\编号	Parts and Quantities\零件及数量	Index\编号	Some parts are spare. Keep them properly. 部分物料有冗余,请妥善保管。
1 x Double-side transparent tape 双面透明胶带 	P46	1 x Seal 封条 	P47	

# Parts List 零件清单 - Upgrade Pack 场地升级包

Parts and Quantities\零件及数量	Index\编号	Parts and Quantities\零件及数量	Index\编号	Parts and Quantities\零件及数量	Index\编号
2 × Flat beam 1550-120 扁铝 1550-120 	P01	4 × Octagonal pillar 4040-250 八棱柱 4040-250 	P07	1 × Board B1 B1 板 	P13
8 × Flat beam 1550-293 扁铝 1550-293 	P02	4 × Octagonal pillar 4040-600 八棱柱 4040-600 	P09	4 × Board B2 B2 板 	P14
12 × Flat beam 1550-560 扁铝 1550-560 	P03	8 × Octagonal pillar cover 八棱柱封盖 	P10	1 × Board C1 C1 板 	P15
8 × Flat beam 1550-960 扁铝 1550-960 	P04	4 × MakeX board A1 A1 红黑护栏板 	P11	2 × Board D1 D1 板 	P16
20 × Flat beam lock 三卡锁 	P06	4 × MakeX board A2 A2 蓝黑护栏板 	P12	1 × Board E1 E1 板 	P17

# Parts List 零件清单- Upgrade Pack 场地升级包

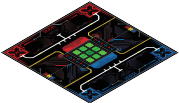
06

Parts and Quantities\零件及数量	Index\编号	Parts and Quantities\零件及数量	Index\编号	Parts and Quantities\零件及数量	Index\编号
1 x Board F1 F1板 	P18	8 x Board J2 J2板 	P23	20 x Slide beam 080 滑轨双孔梁 080 	P28
8 x Board G1 G1板 	P19	2 x Board K1 K1板 	P24	1 x Square mesh 方形网 	P29
2 x Board H1 H1板 	P20	8 x Board L1 L1板 	P25	1 x Map 地图 	P30
2 x Board I1 I1板 	P21	165 x Screw M4*8 螺丝 M4*8 	P26	6 x Blue ball 蓝色球 	P31
2 x Board J1 J1板 	P22	20 x Slide beam 016 滑轨双孔梁 016 	P27	6 x Red ball 红色球 	P32

# Parts List 零件清单 - Upgrade Pack 场地升级包

Parts and Quantities\零件及数量	Index\编号	Parts and Quantities\零件及数量	Index\编号	Parts and Quantities\零件及数量	Index\编号
14 x Yellow ball 黄色球 	P33	4 x Transparent square box 透明方盒 	P38	1 x Transparent tape 透明胶带 	P46
3 x Yellow cube 70 mm 黄色方块 70 mm 	P34	8 x Sticker 1 贴纸 1 	P41	1 x Seal 封条 	P47
17 x Red cube 70 mm 红色方块 70 mm 	P35	1 x Sticker 2 贴纸 2 	P42	<p><b>Note:</b> If you purchase the MakeX Explorer Arena Upgrade Kit for Strategy Front, you need to use it in combination with the 2024 Explorer Arena Pack to complete the assembly of the arena.</p> <p><b>注意:</b> 如您购买的是 MakeX Explorer 博弈前线_场地升级包, 则需配合 2024 MakeX Explorer 数智先锋场地套装完成搭建。</p>	
17 x Blue cube 70 mm 蓝色方块 70 mm 	P36	1 x Screwdriver 3.0 mm 螺丝刀 3.0 mm 	P44		
4 x Yellow cube 120 mm 黄色方块 120 mm 	P37	1 x Double-sided fabric tape 双面布基胶带 	P45		

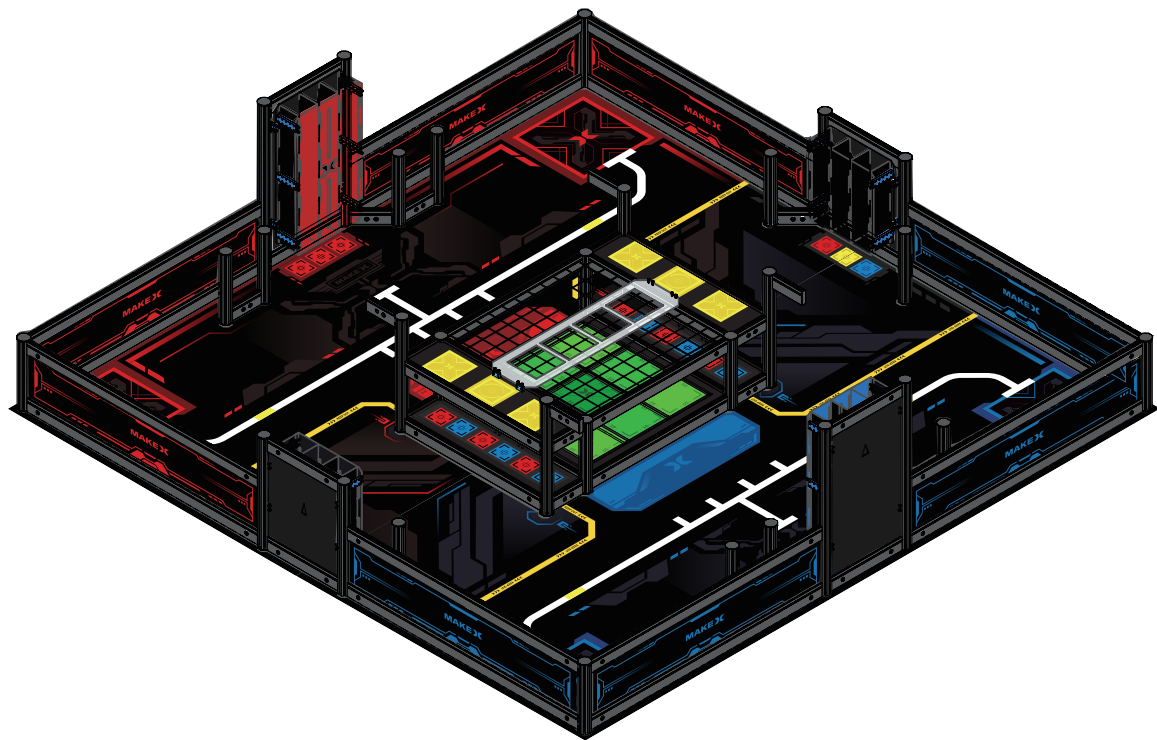

S01

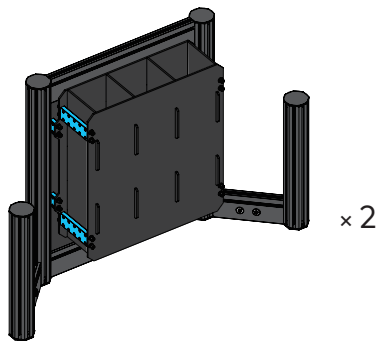

S02

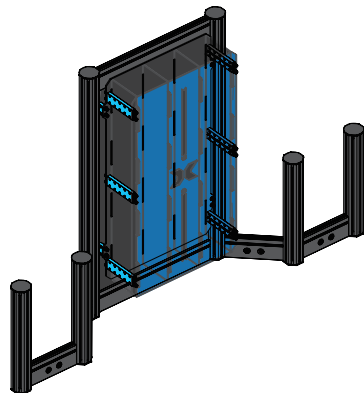

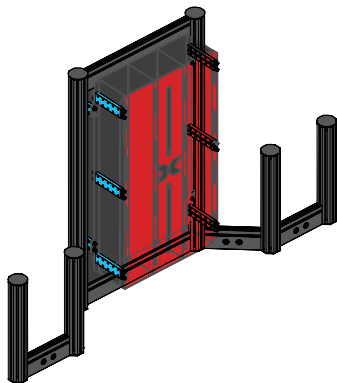

S03



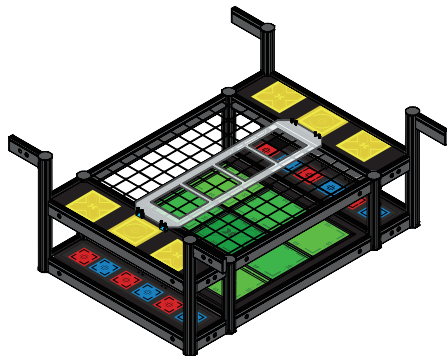

S04

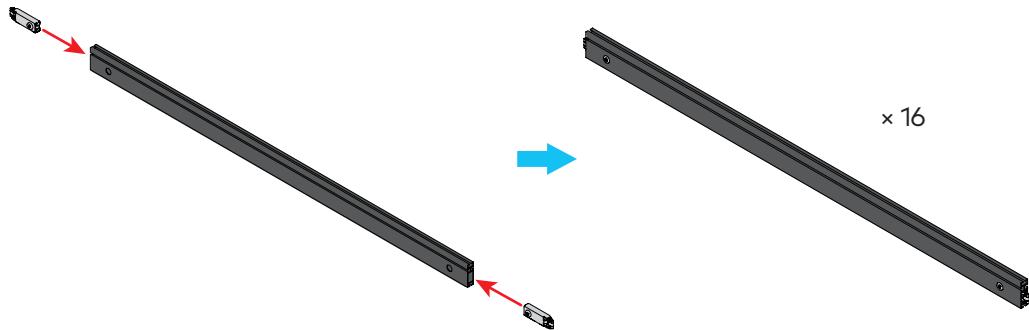

# Frame Assembly 边框搭建

- 16x  P04
- 32x  P06



- 4x  P07
- 4x  P10

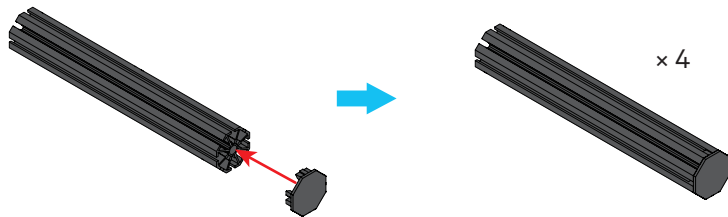

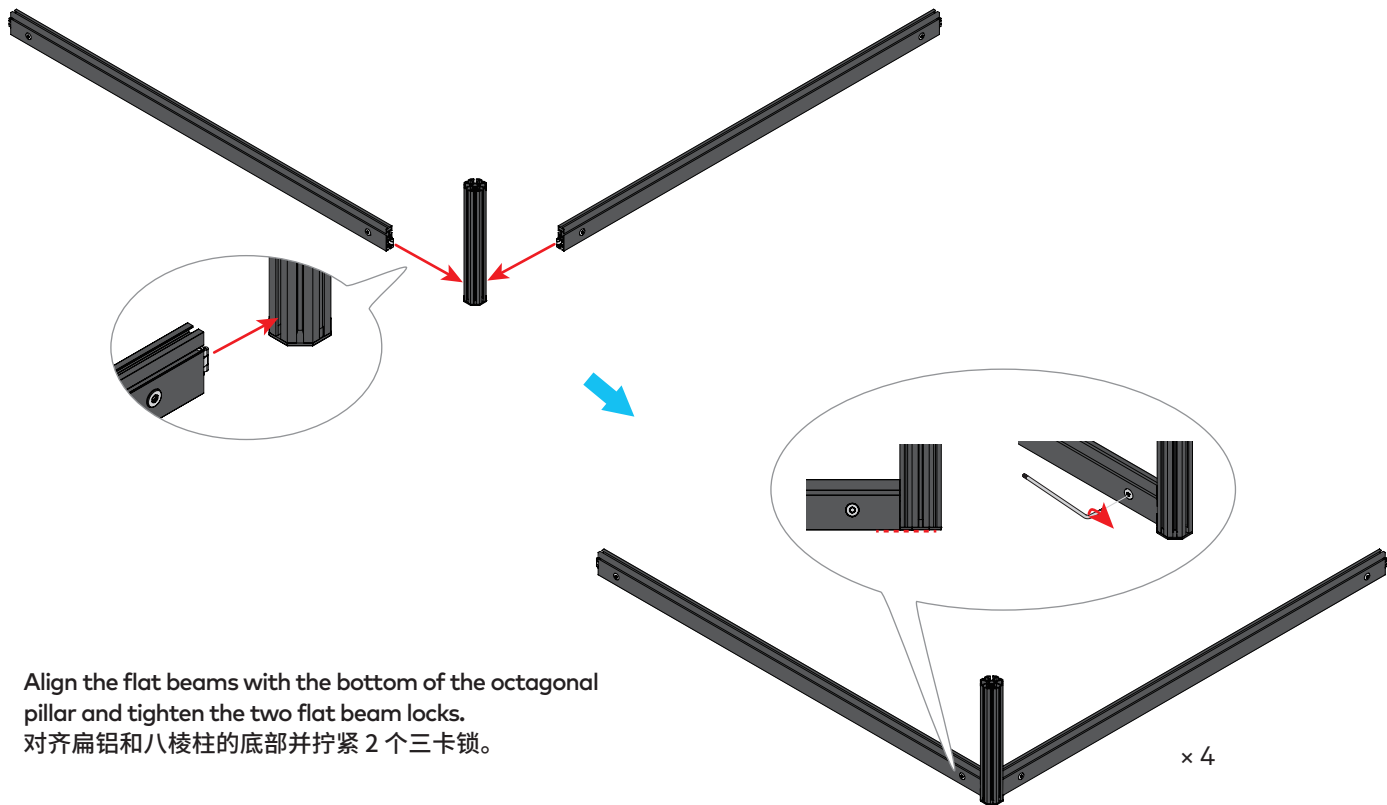

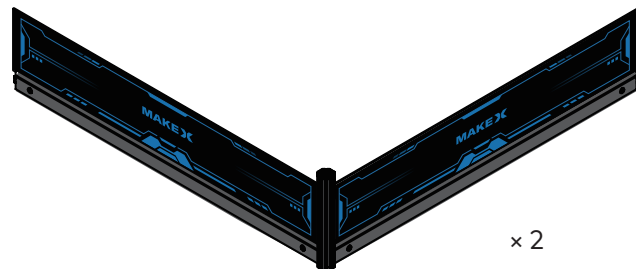
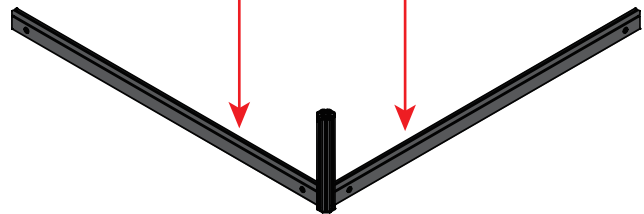
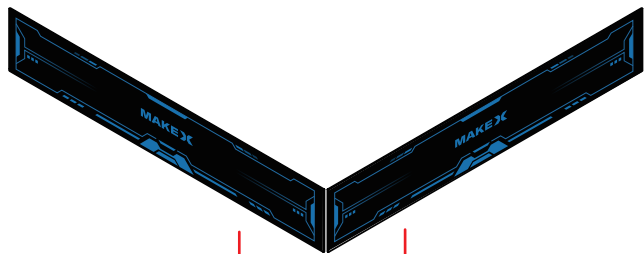
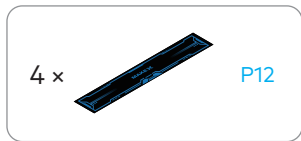

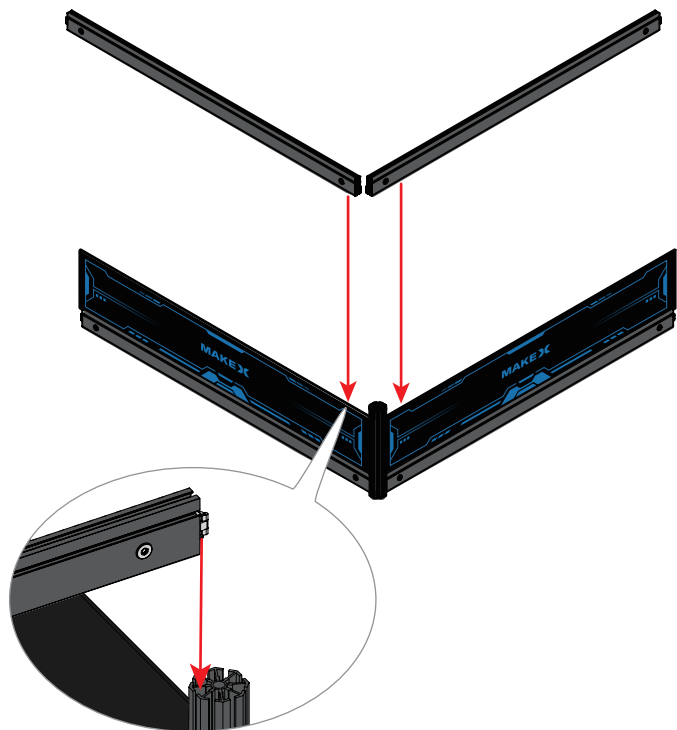

Align the flat beams with the top of the octagonal pillar and tighten the two flat beam locks.

对齐扁铝和八棱柱的顶部并拧紧 2 个三卡锁。

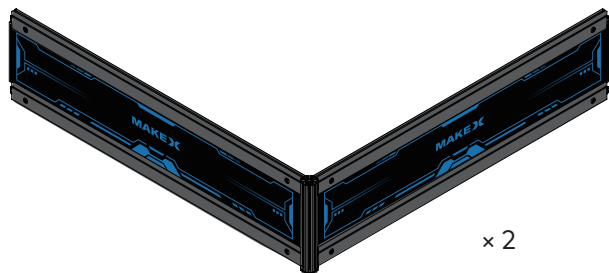

x 2

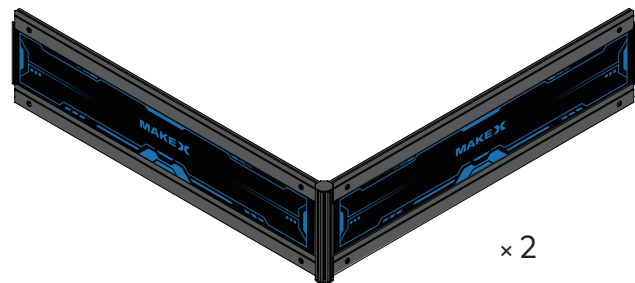
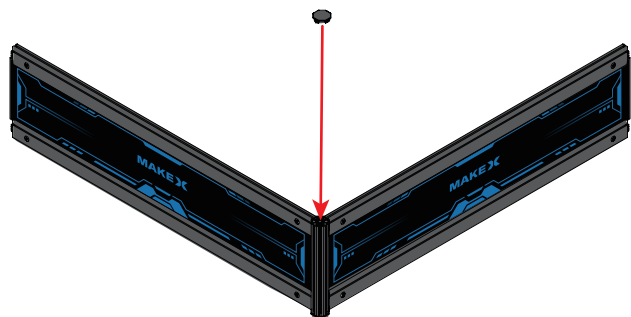
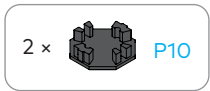

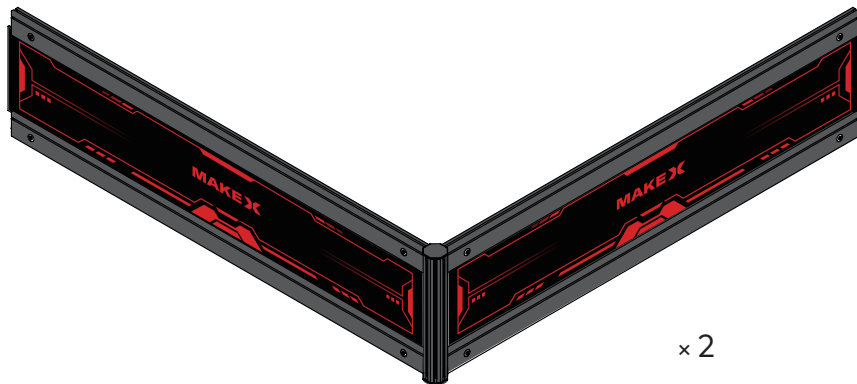

## Frame Assembly 边框搭建

Assemble MakeX boards A1 in the same way.  
以同样的方式组装 A1 红黑护栏板。



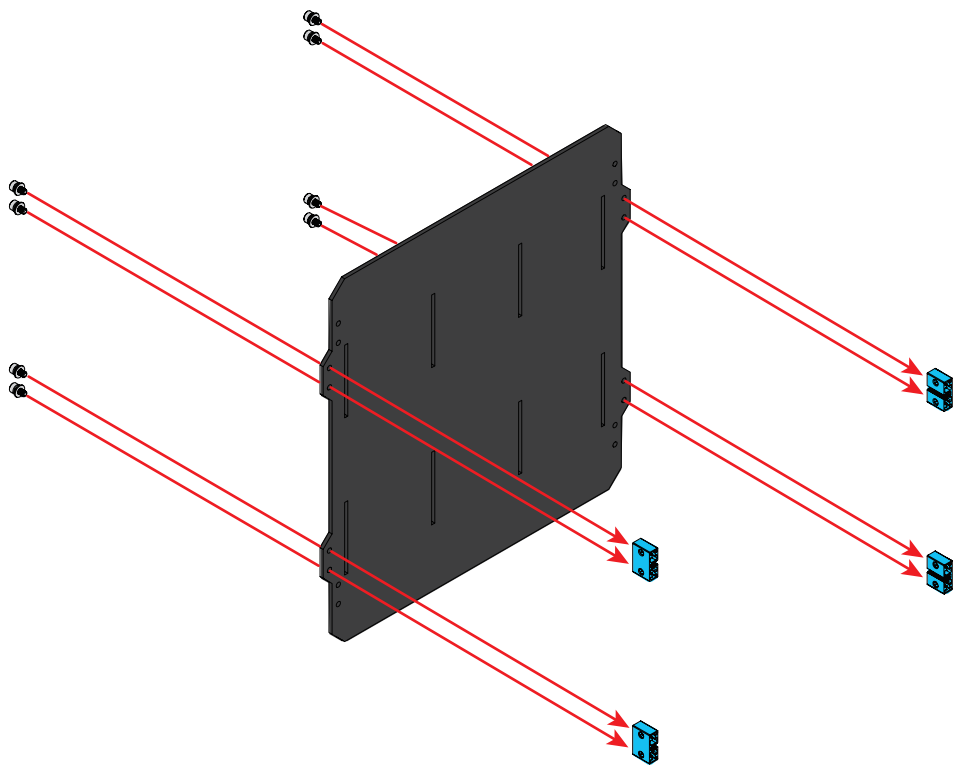

# S01 Assembly S01 搭建

- 1 ×  P24
- 4 ×  P27
- 8 ×  P26



# S01 Assembly S01 搭建

- 4 x  P28
- 8 x  P26

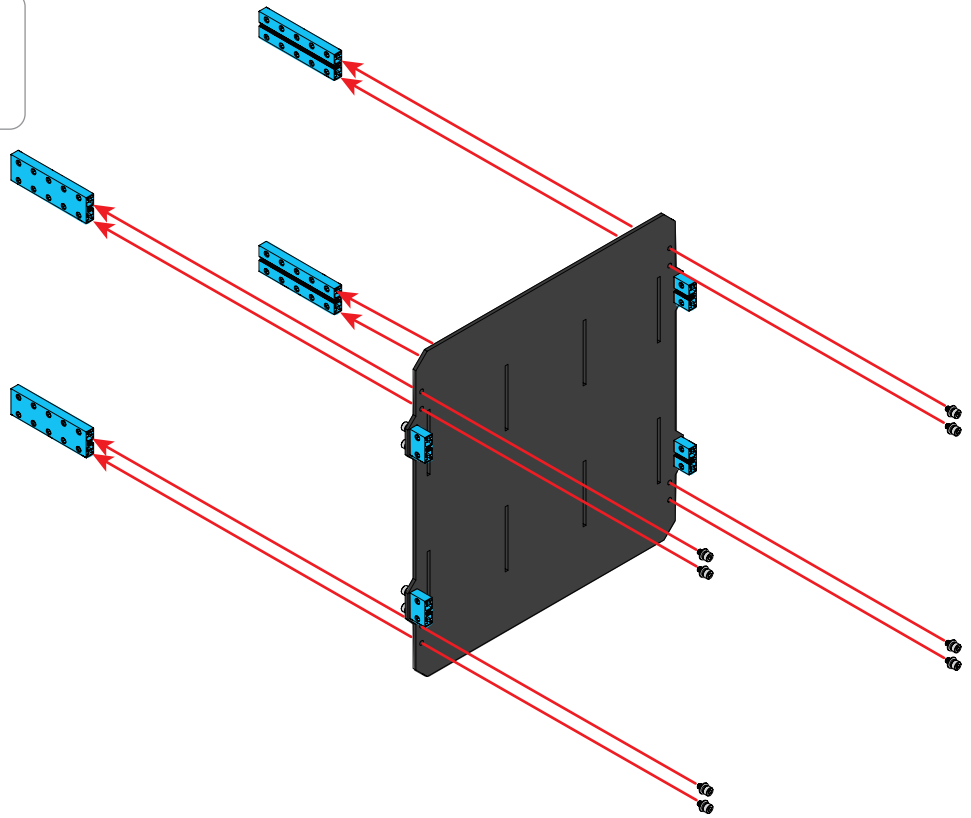

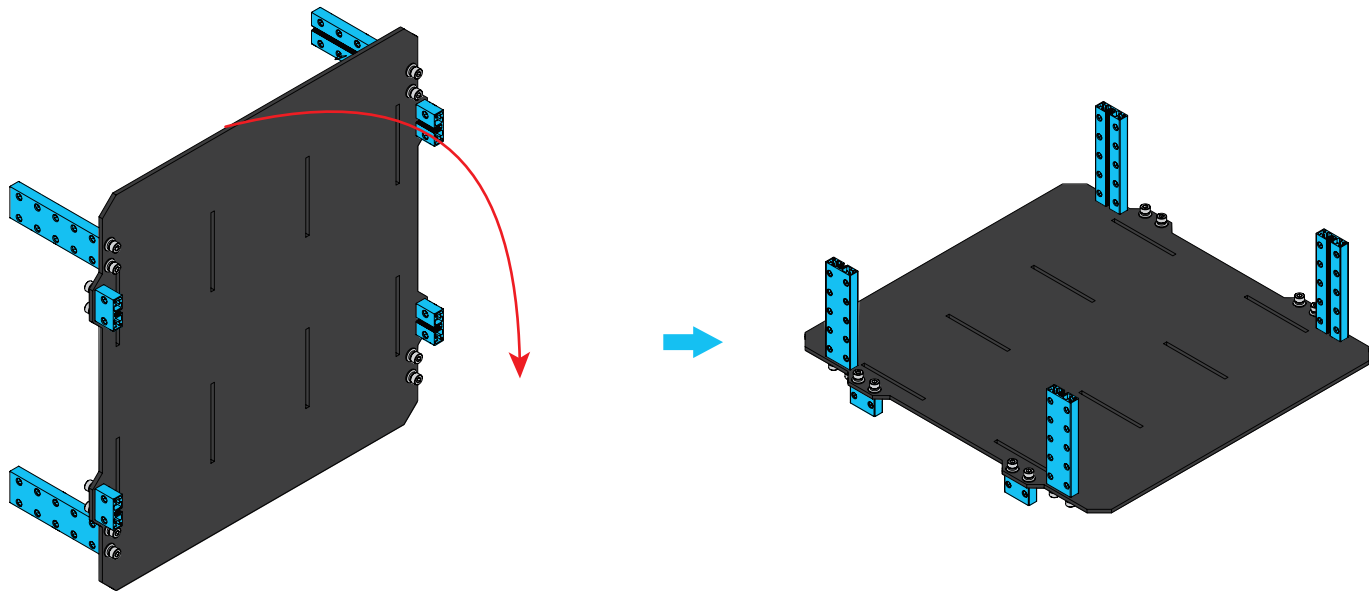

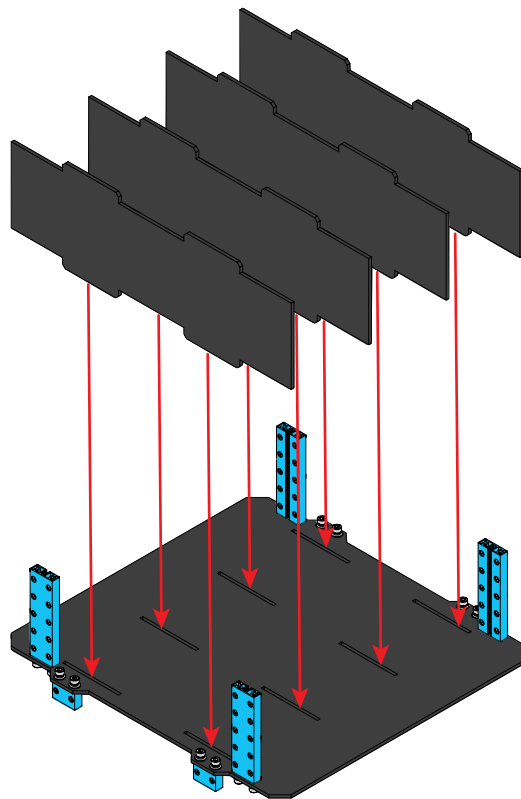
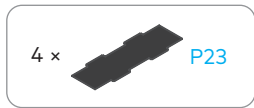

# S01 Assembly S01 搭建

- 1 ×  P22
- 8 ×  P26

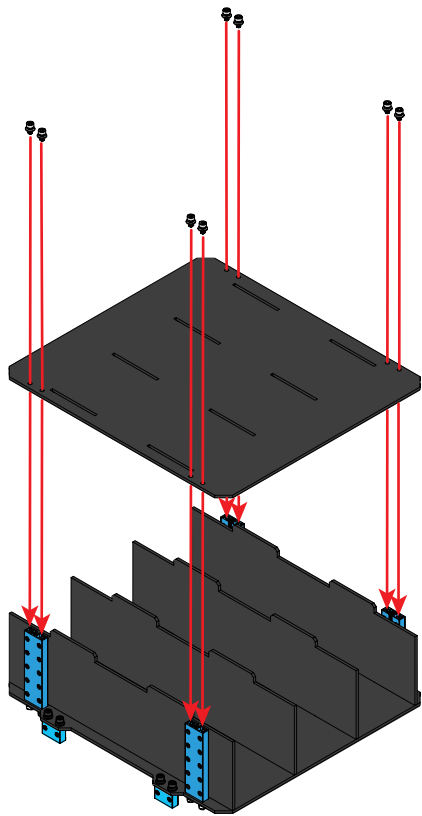

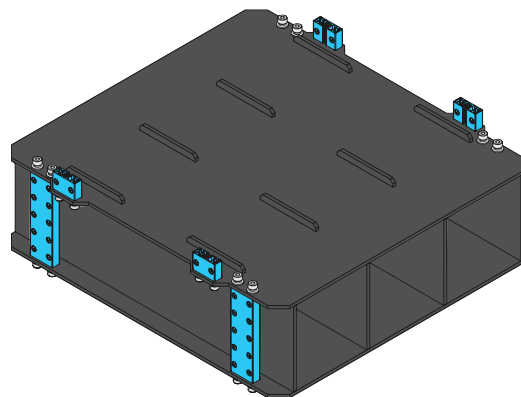
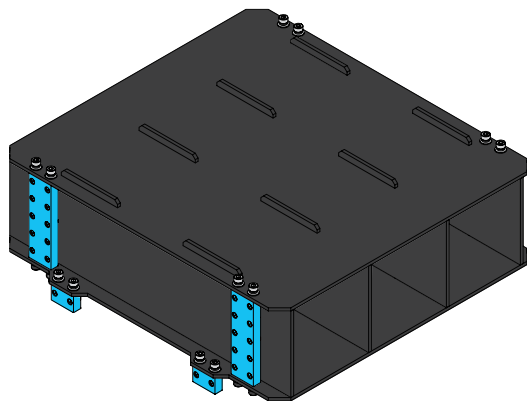

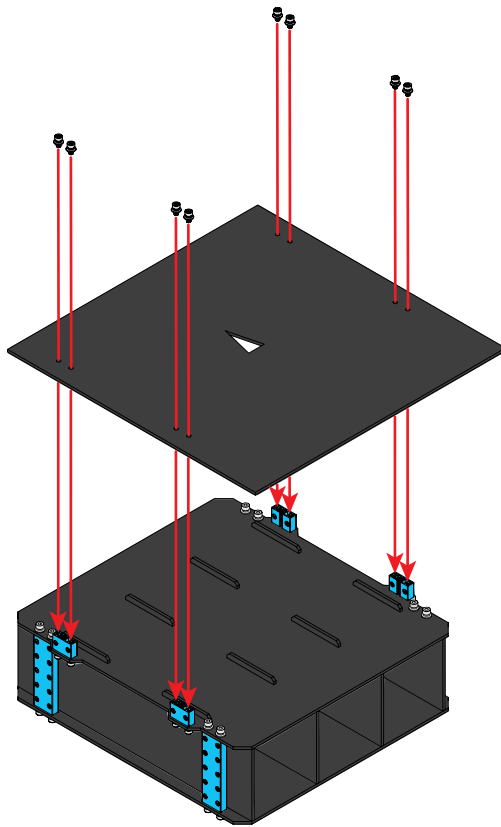

# S01 Assembly S01 搭建

- 1 ×  P21
- 8 ×  P26

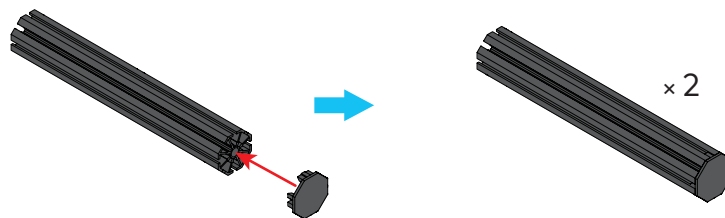
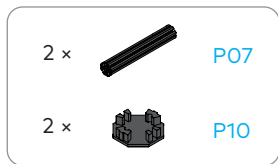
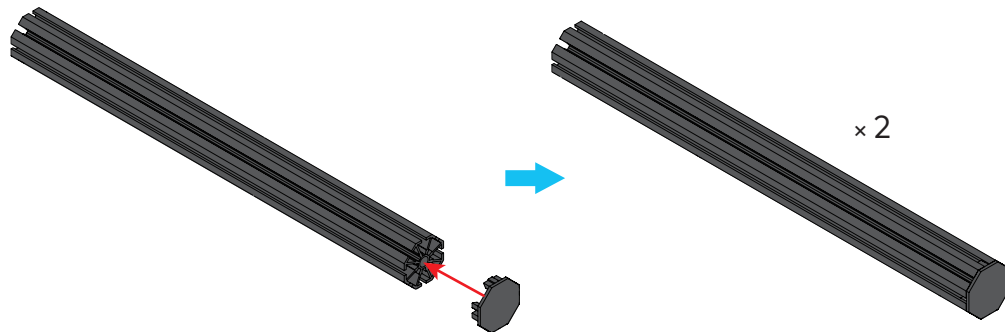
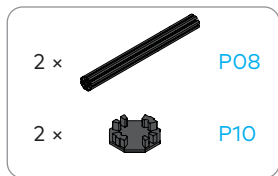



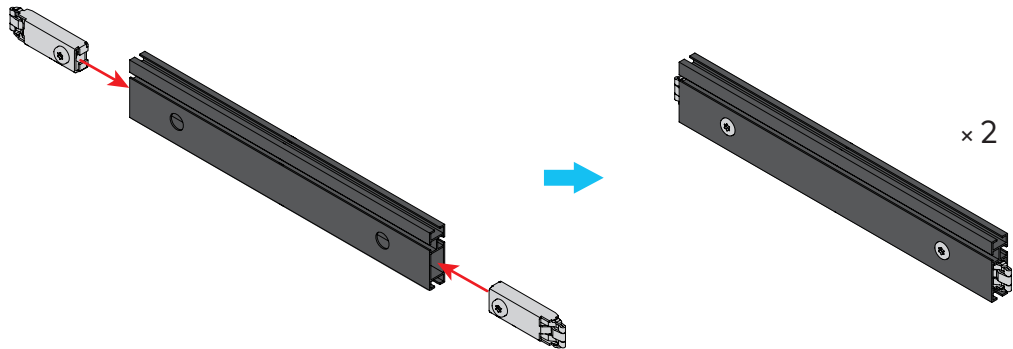

# S01 Assembly S01 搭建

- 2 x  P02
- 4 x  P06



- 2 x  P01
- 4 x  P06

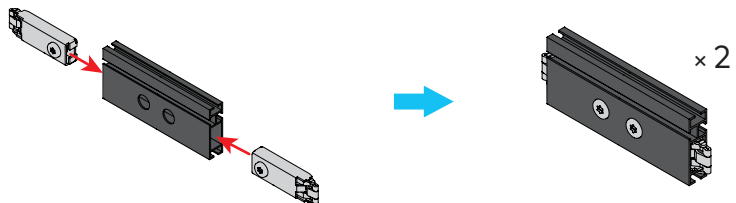

## S01 Assembly S01 搭建

Align the flat beams with the bottom of the octagonal pillar  
and tighten the two flat beam locks.

对齐扁铝和八棱柱的底部并拧紧 2 个三卡锁。

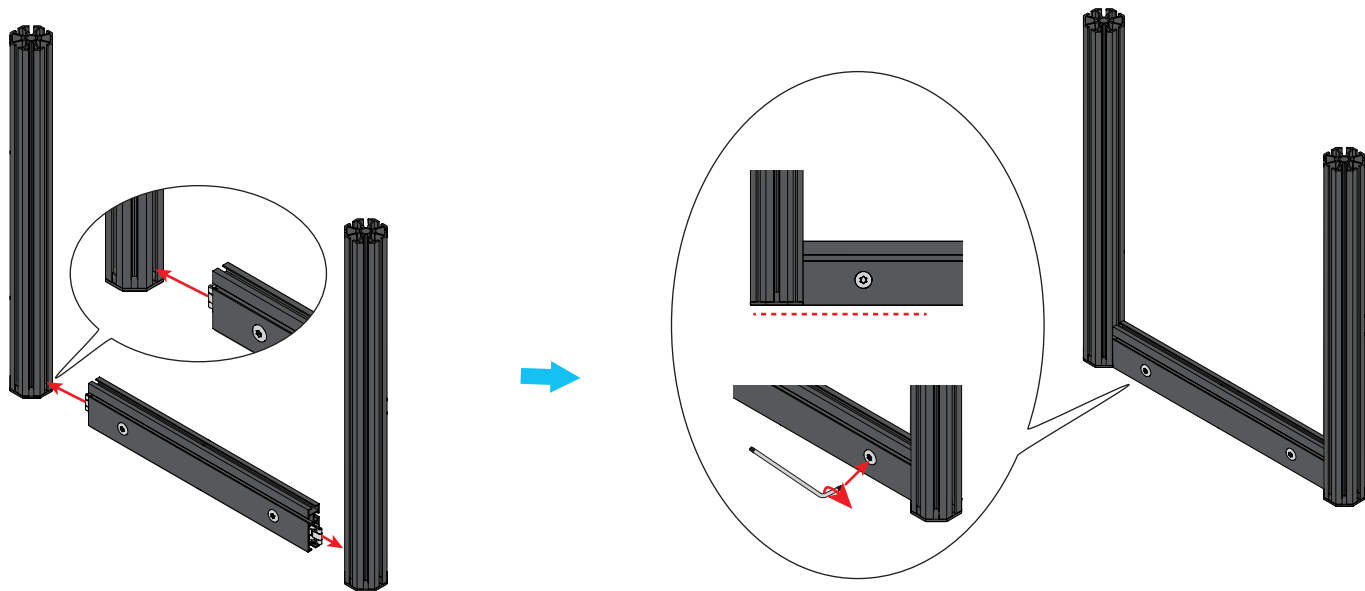

## S01 Assembly S01 搭建

26

Align the flat beams with the bottom of the octagonal pillar and tighten the flat beam locks.

对齐八棱柱和扁铝的底部并拧紧三卡锁。



Pay attention to the direction of the flat beams.

安装时注意扁铝的方向。

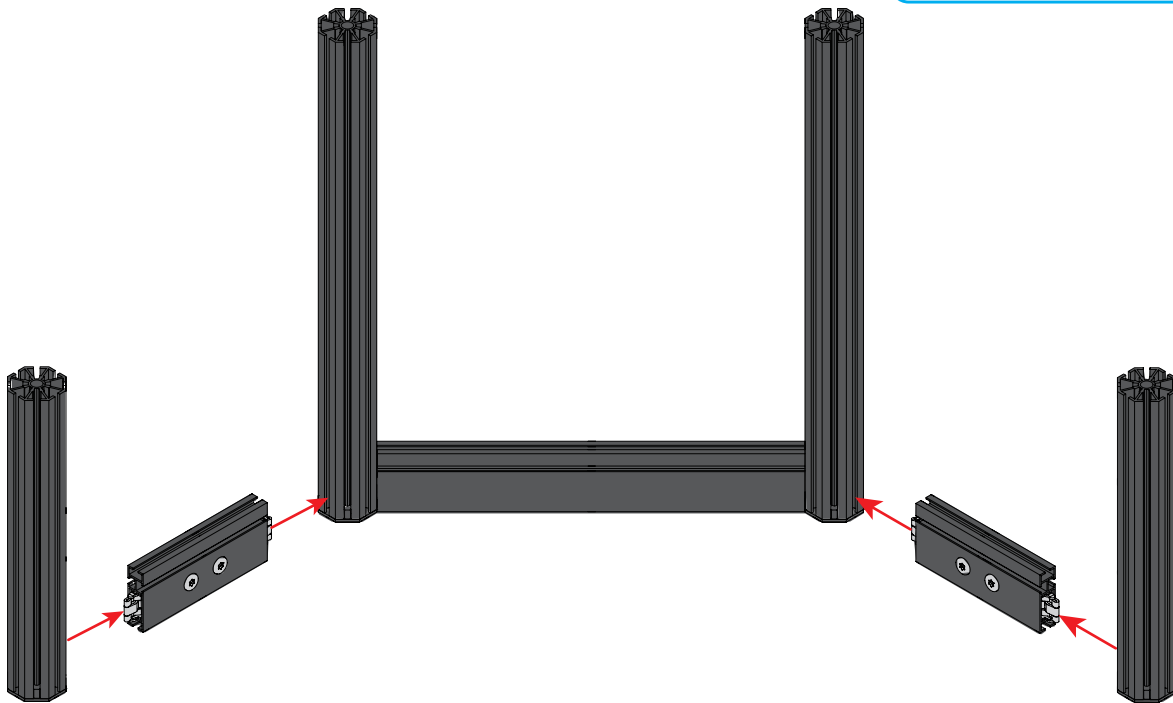

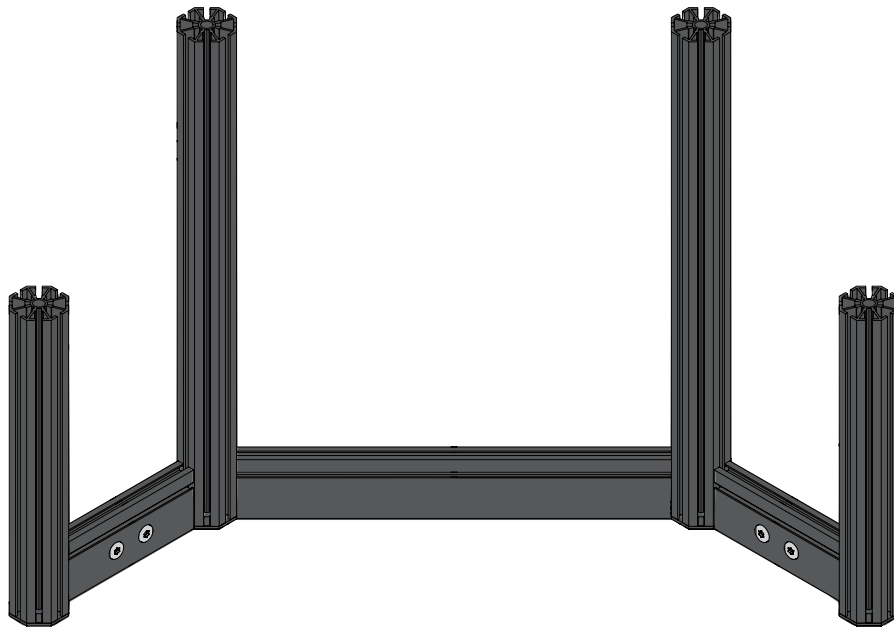

08  
09

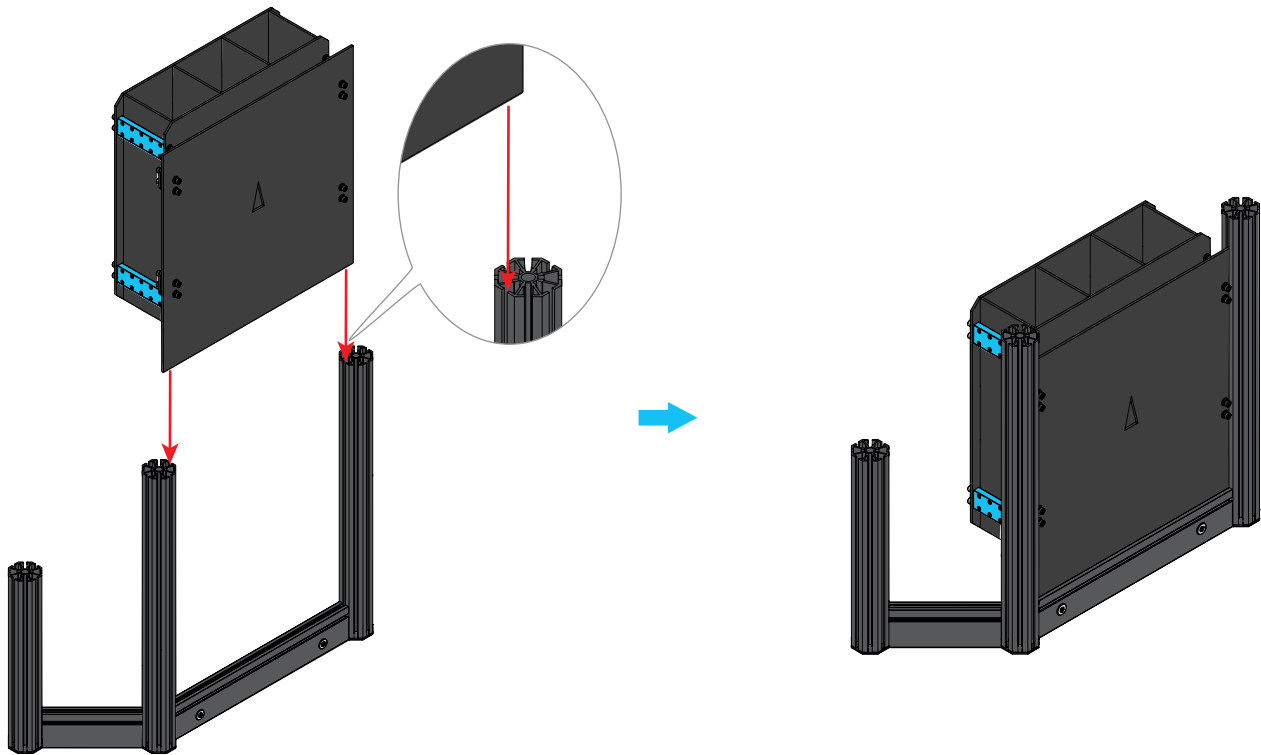

## S01 Assembly S01 搭建

Align the flat beam with the tops of the octagonal pillars and tighten the two flat beam locks.

对齐扁铝和八棱柱的顶部并拧紧 2 个三卡锁。

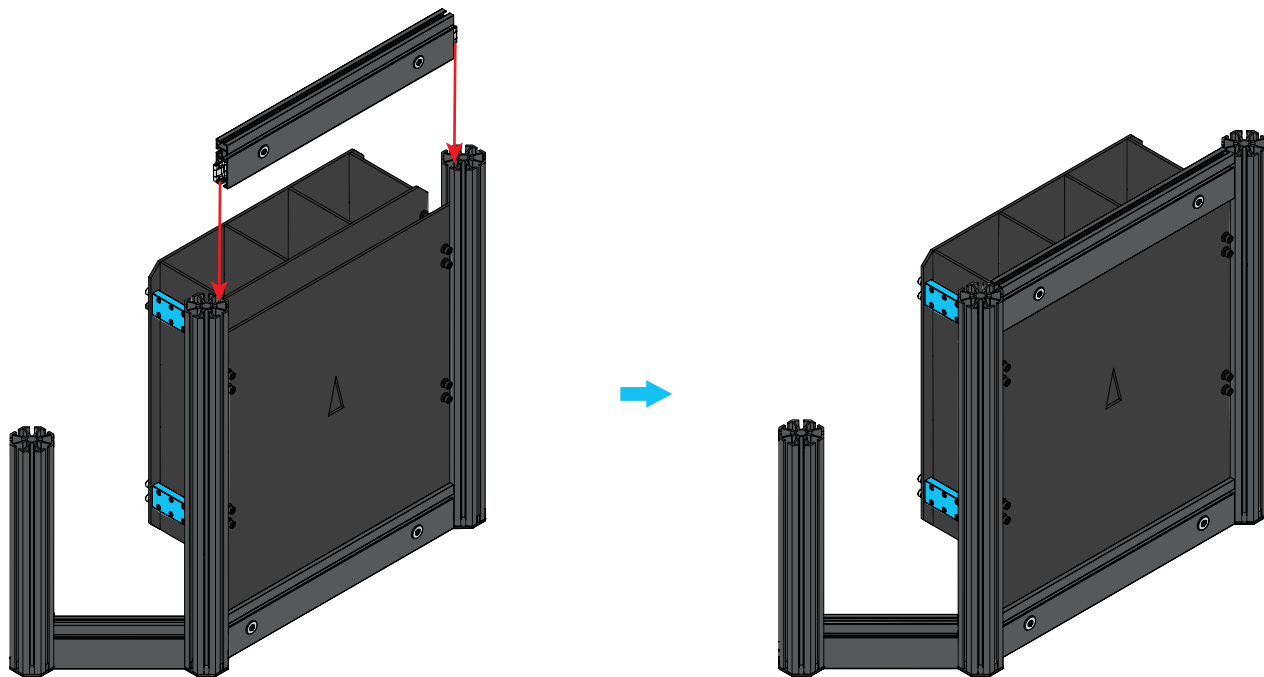

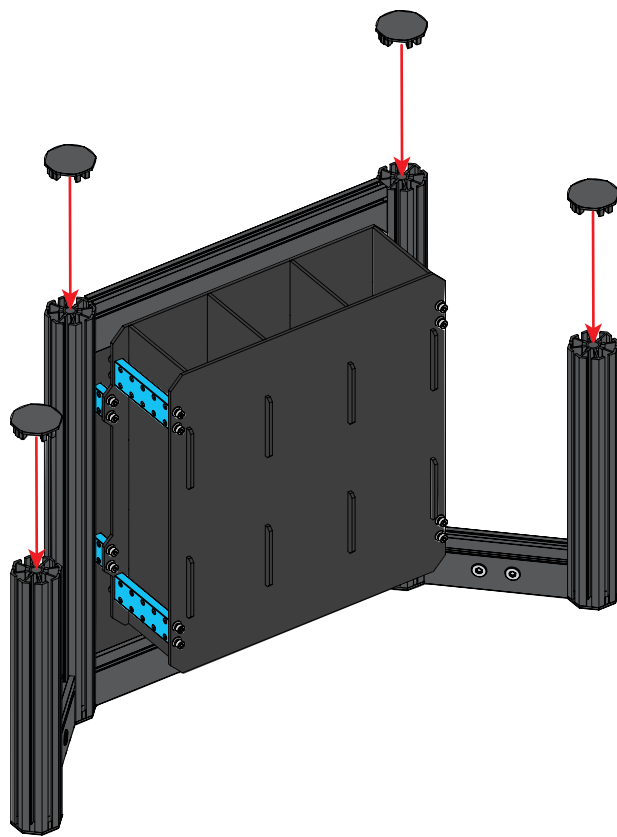
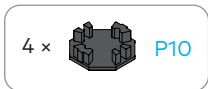

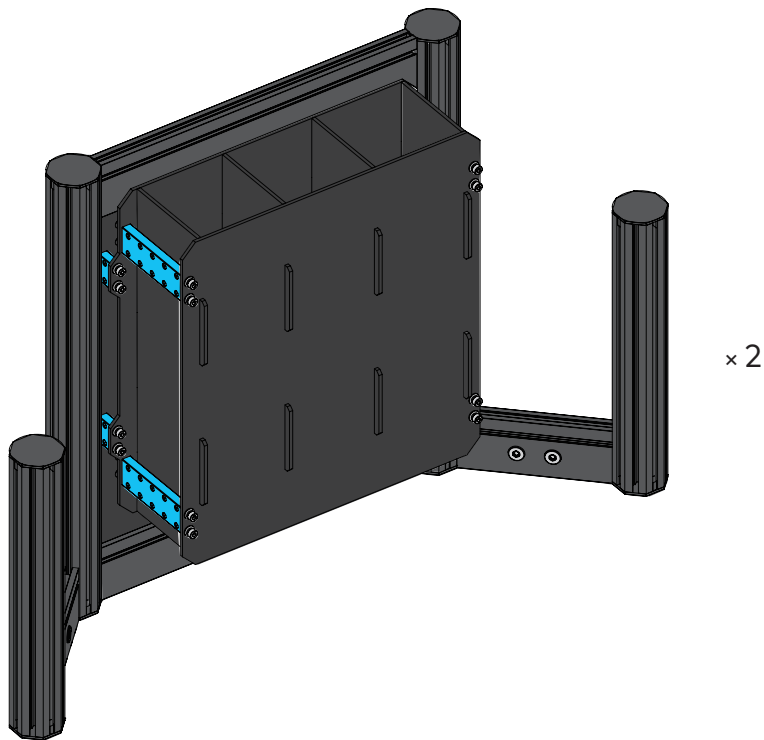

## S01 Assembly S01 搭建

Assemble the other S01 in the same way.  
以同样的方式安装另一个 S01。





## S02 Assembly S02 搭建

32

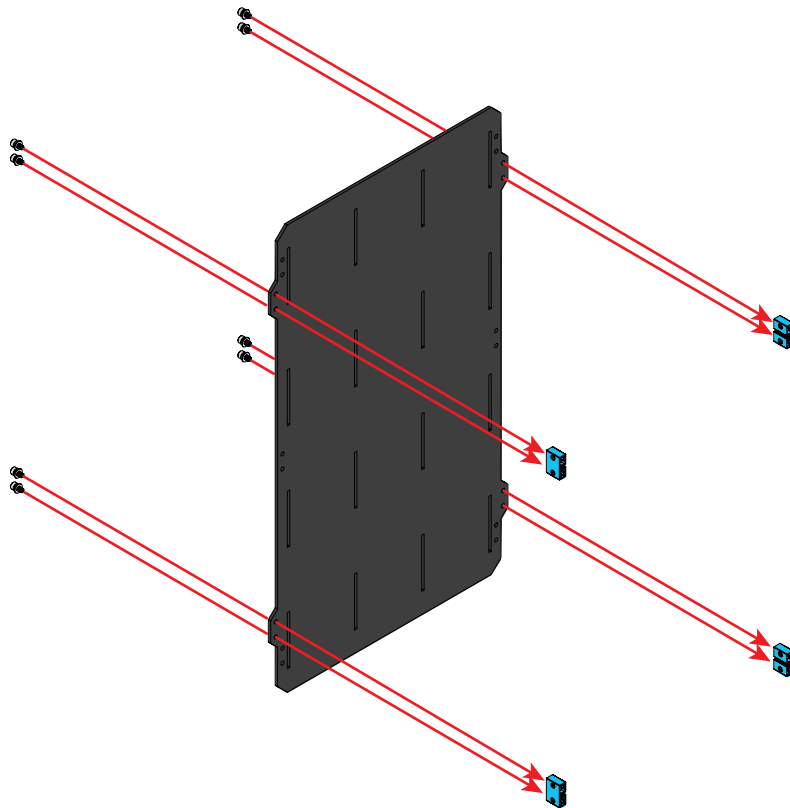
- 1 x  P20
- 4 x  P27
- 8 x  P26



# S02 Assembly S02 搭建

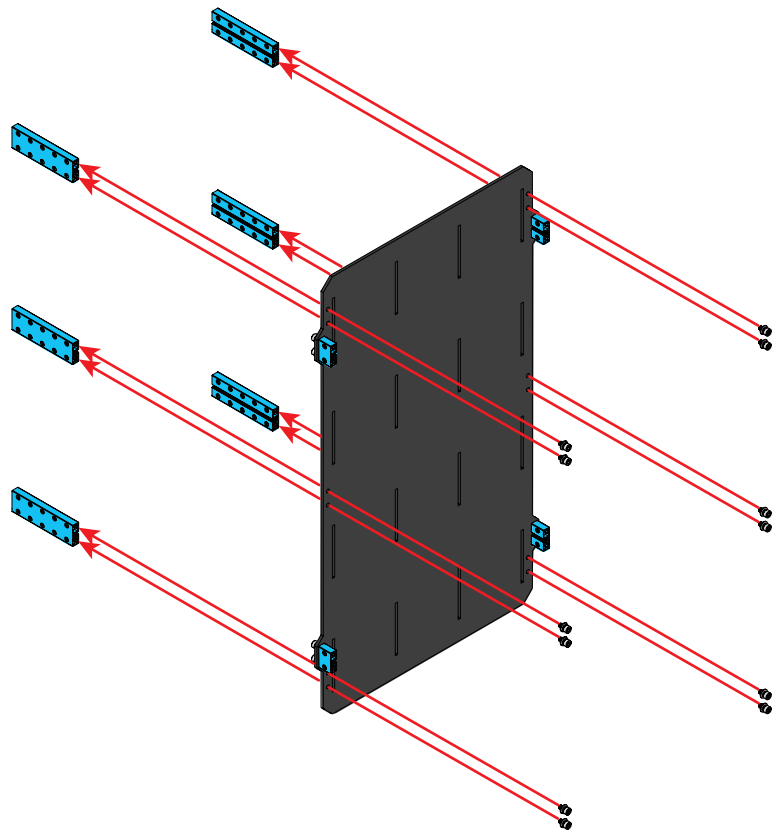

- 6 x  P28
- 12 x  P26

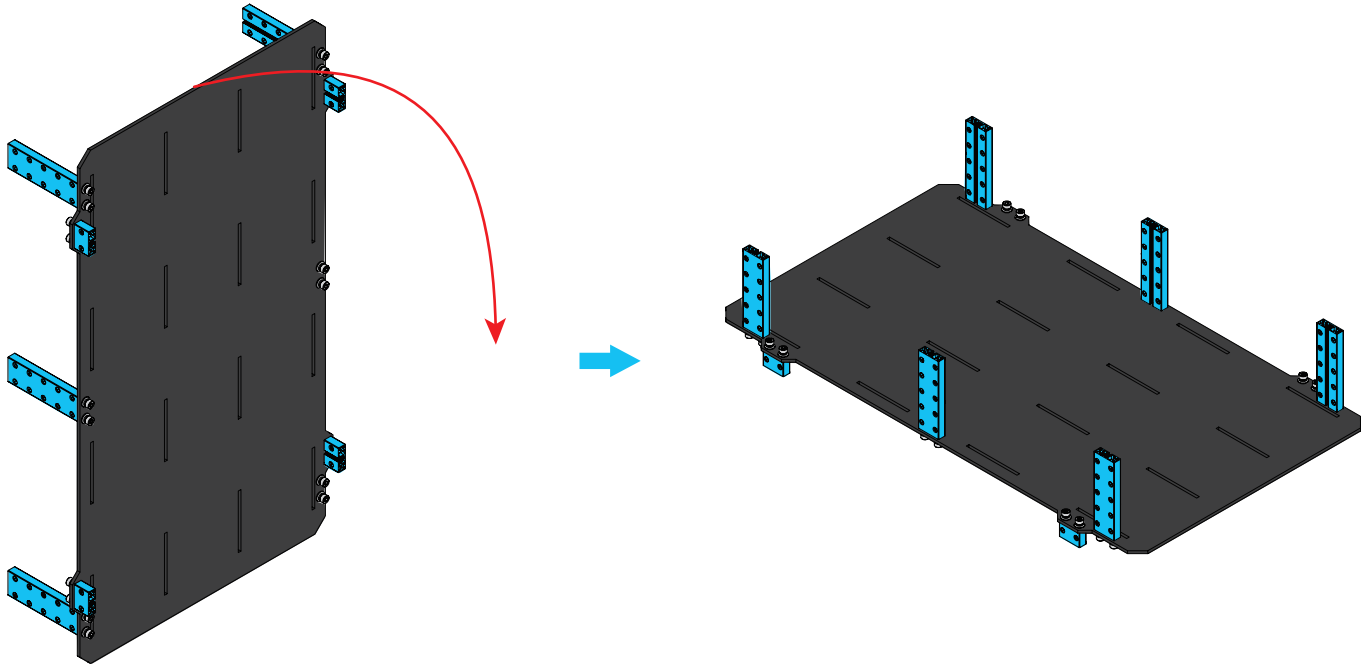

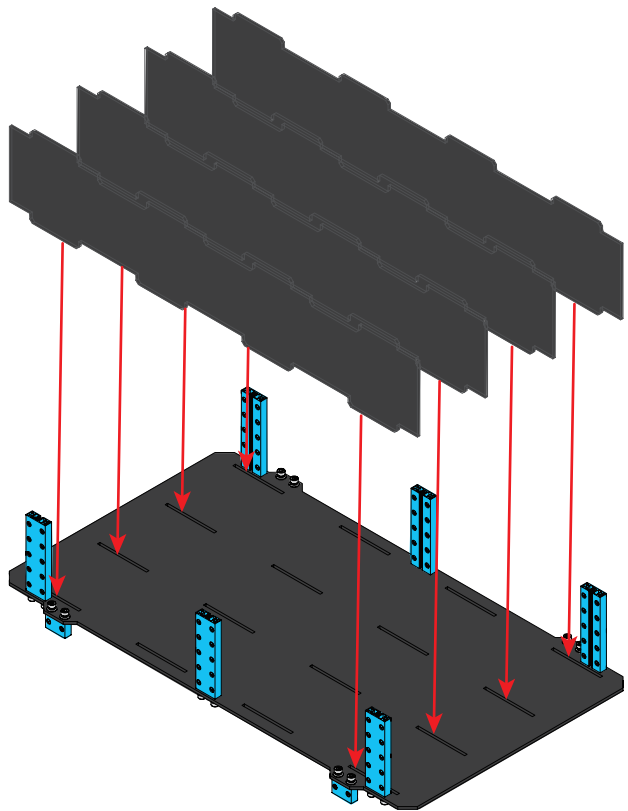



# S02 Assembly S02 搭建

- 1 ×  P18
- 12 ×  P26

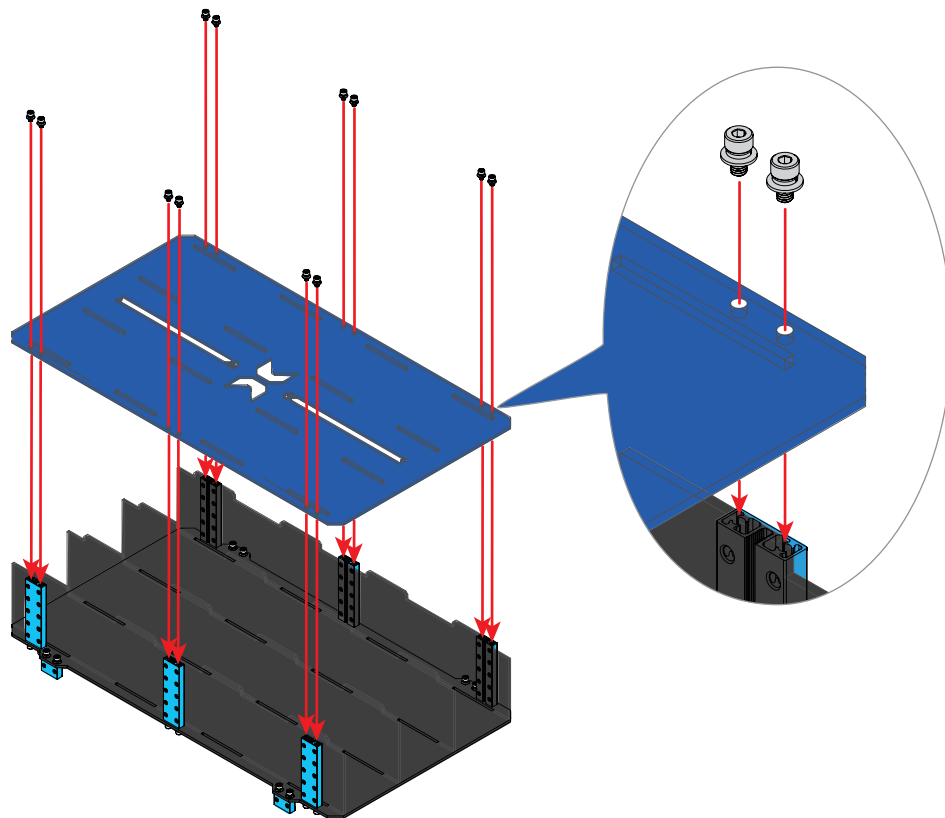

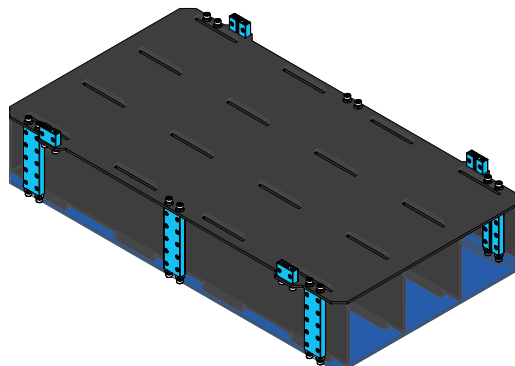
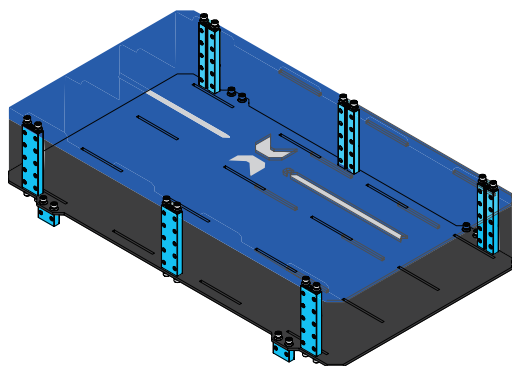



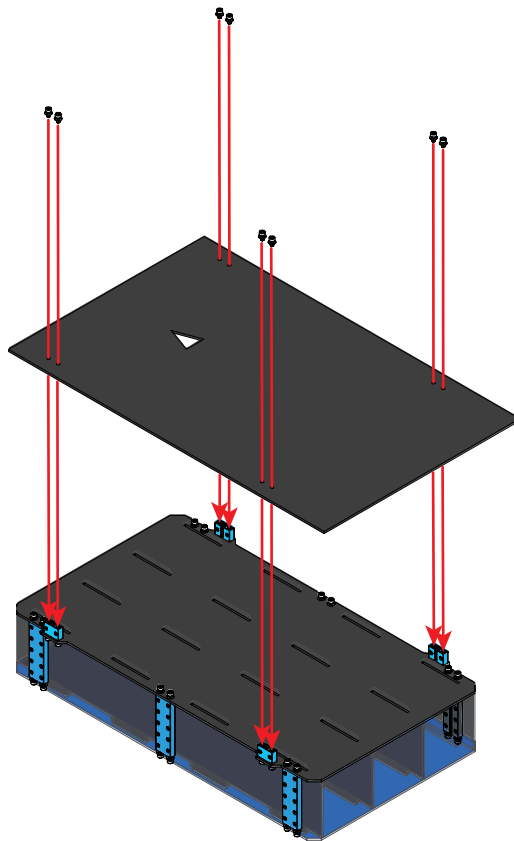
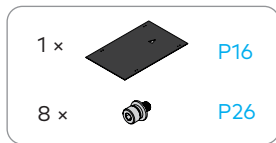

## S02 Assembly S02 搭建



# S02 Assembly S02 搭建

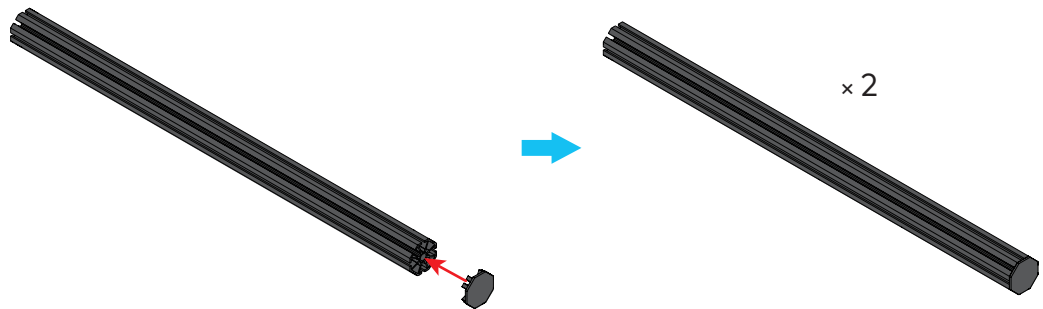

- 2 x  P09
- 2 x  P10



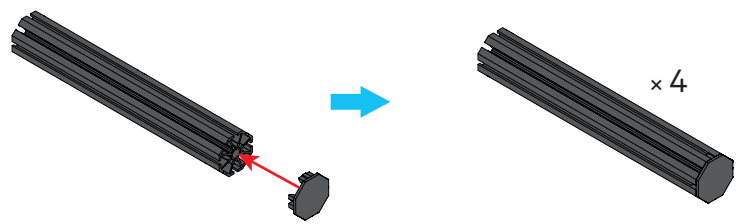

- 4 x  P07
- 4 x  P10

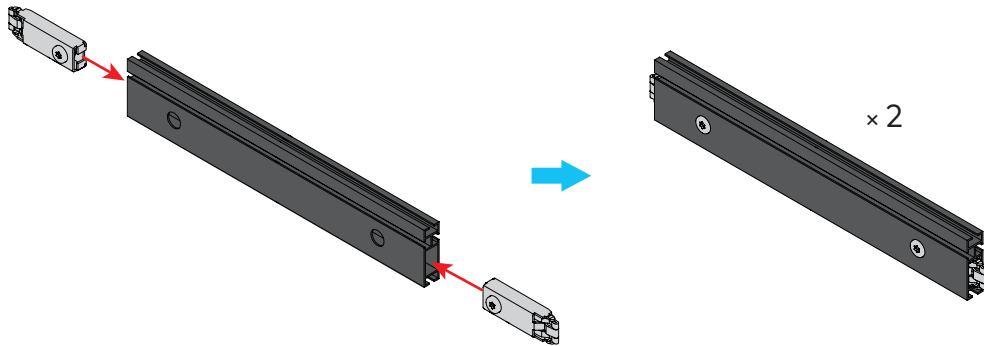

# S02 Assembly S02 搭建

- 2 x  P02
- 4 x  P06



- 4 x  P01
- 8 x  P06

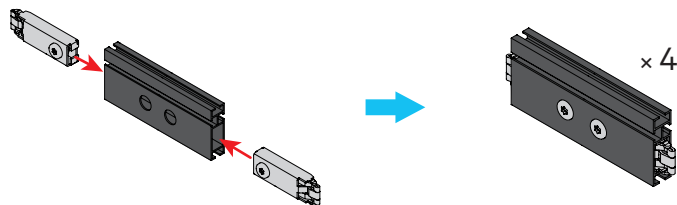

## S02 Assembly S02 搭建

Align the flat beam with the bottoms of the octagonal pillars and tighten the two flat beam locks.

对齐扁铝和八棱柱的底部并拧紧 2 个三卡锁。

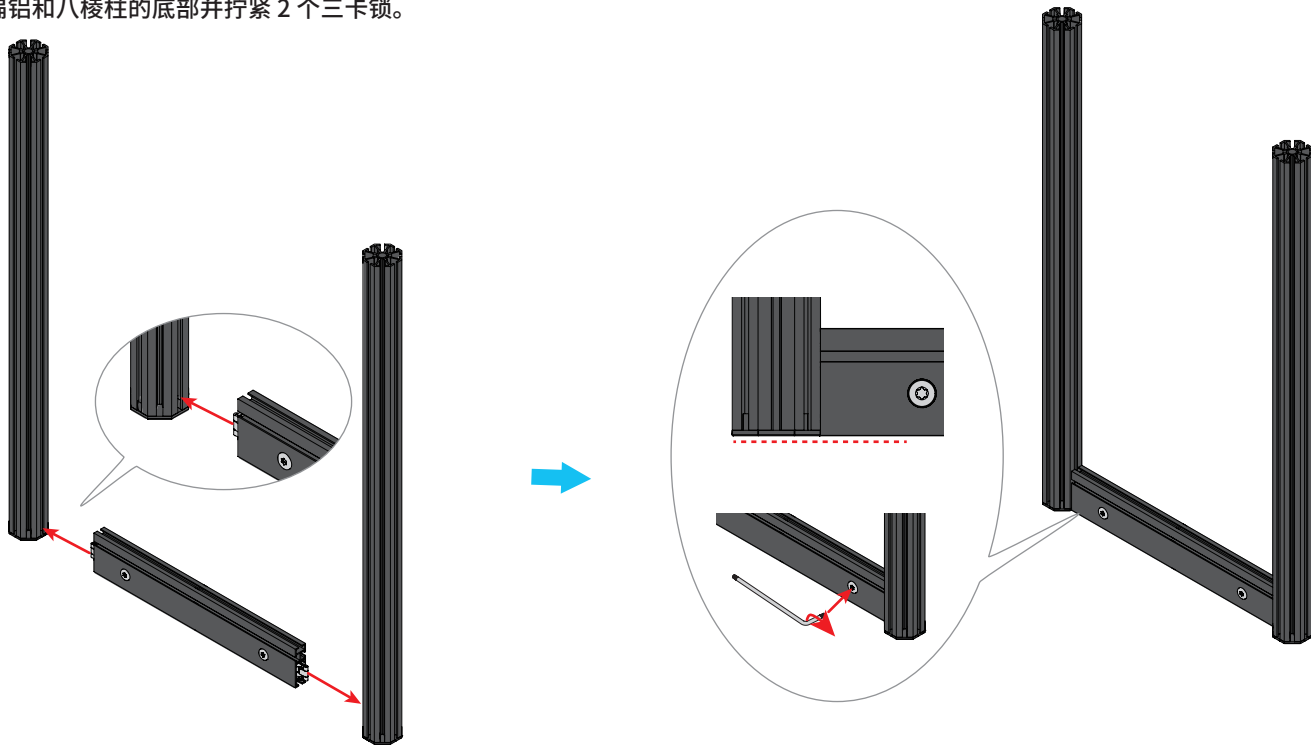

## S02 Assembly S02 搭建

42

Align the flat beam with the bottoms of the octagonal pillars and tighten the two flat beam locks.  
对齐扁铝和八棱柱的底部并拧紧 2 个三卡锁。

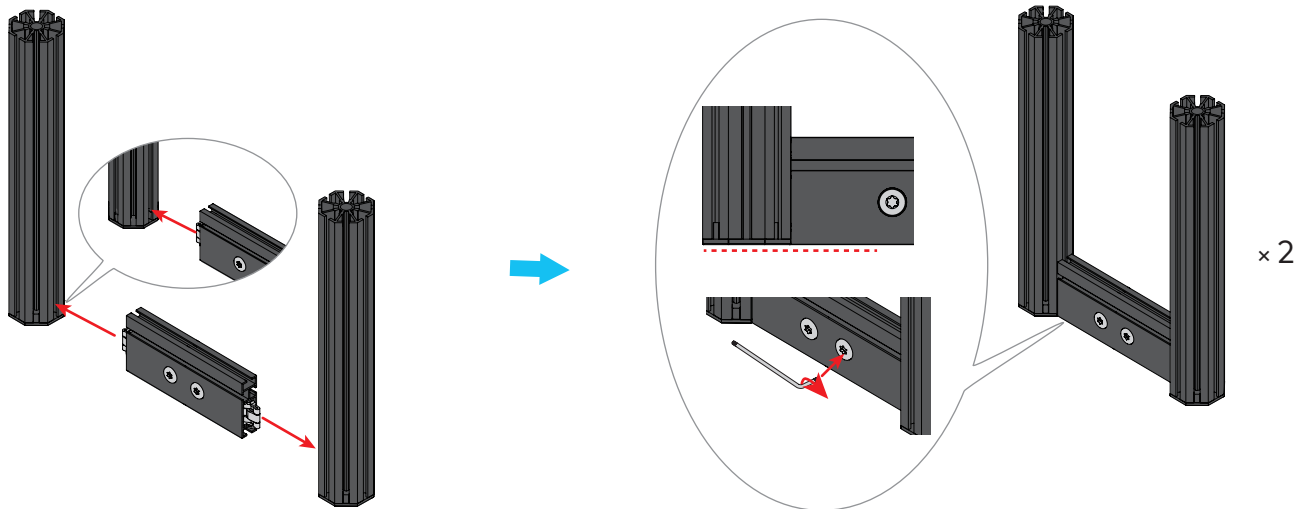

## S02 Assembly S02 搭建

43

Align the flat beams with the bottoms of the octagonal pillars and tighten the four flat beam locks.  
对齐扁铝和八棱柱的底部并拧紧 4 个三卡锁。



Pay attention to the direction of the flat beams.

安装时注意扁铝的方向。

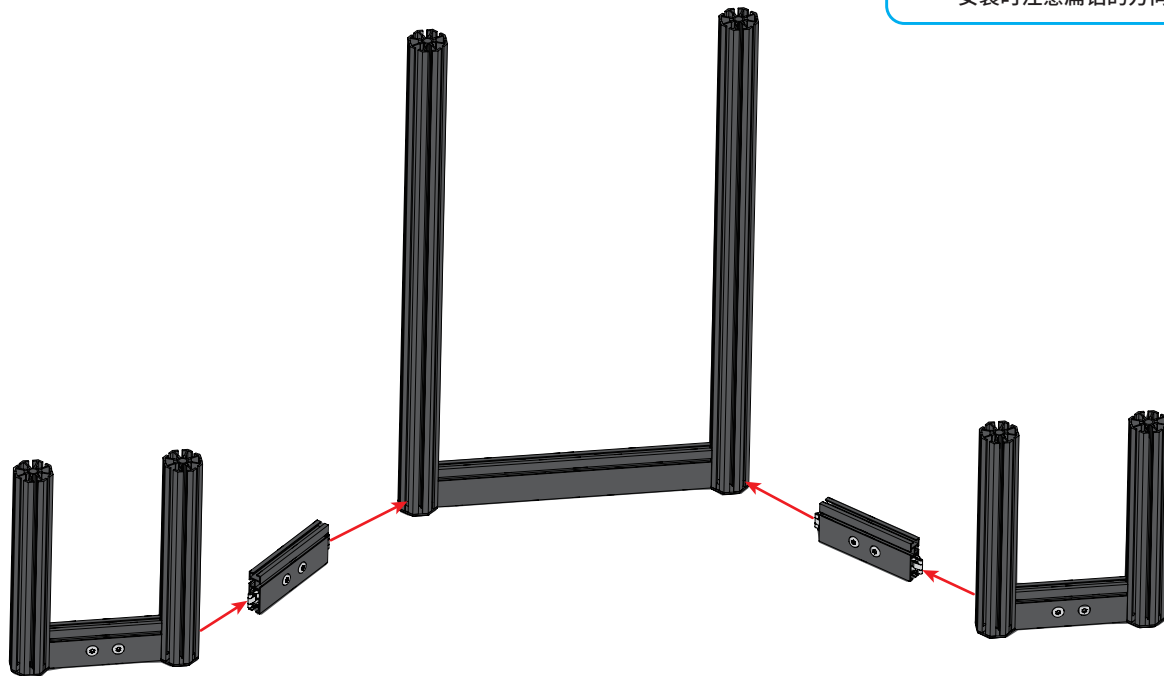



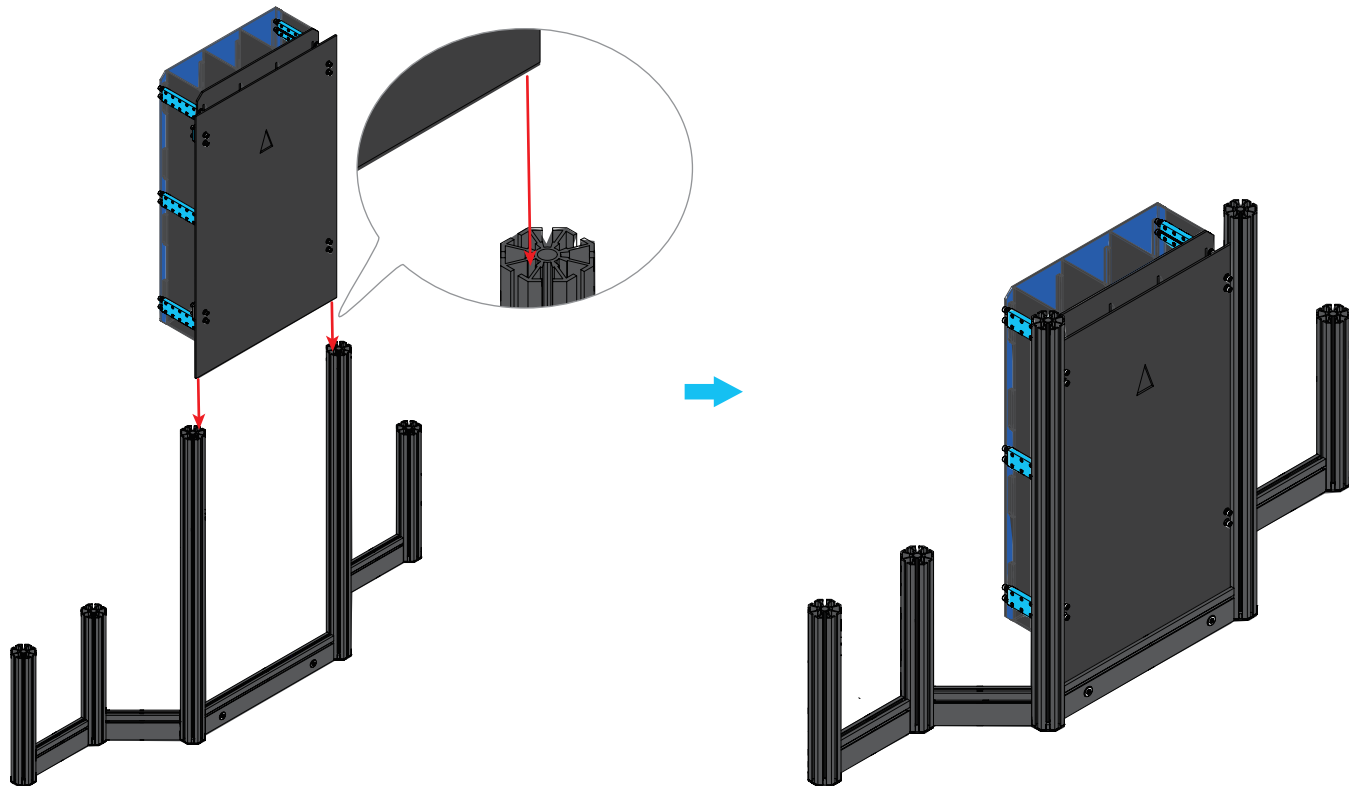

## S02 Assembly S02 搭建

46

Align the flat beam with the tops of the octagonal pillars and tighten the two flat beam locks.

对齐扁铝和八棱柱的顶部并拧紧 2 个三卡锁。

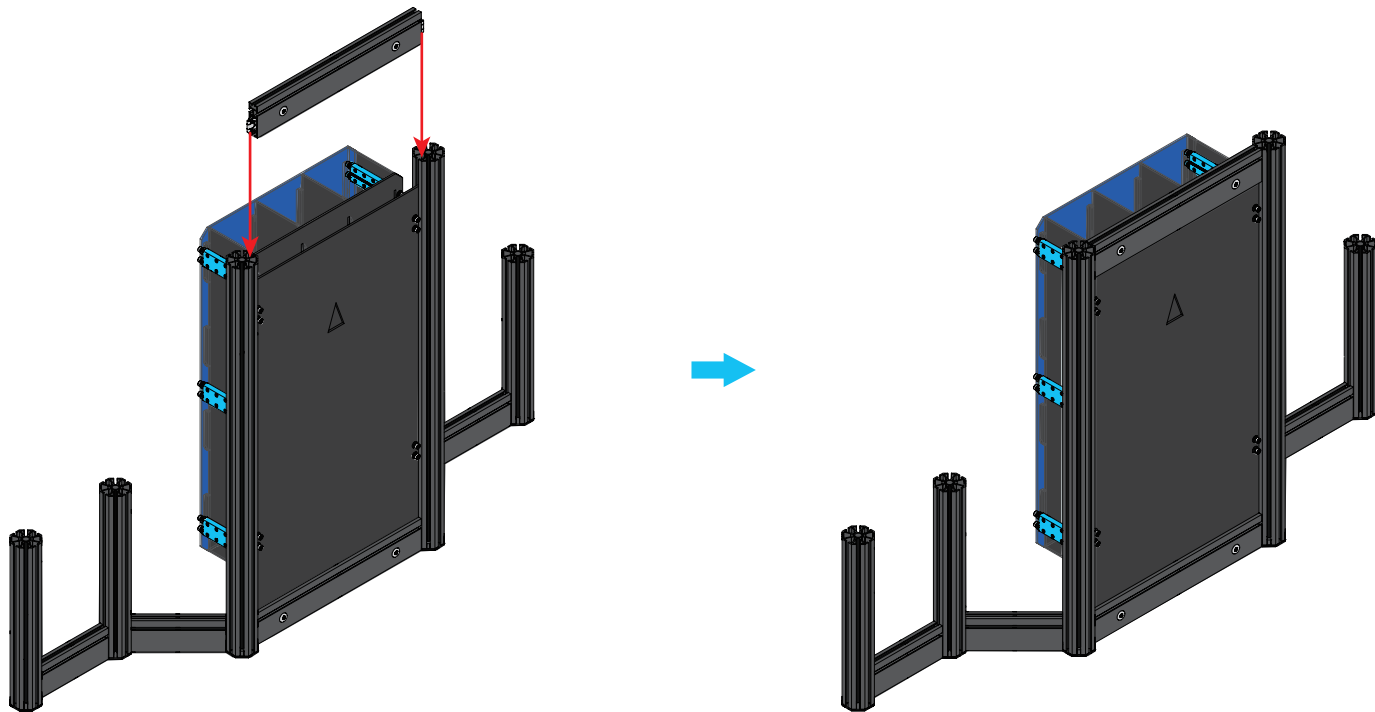

# S02 Assembly S02 搭建

6 x  P10

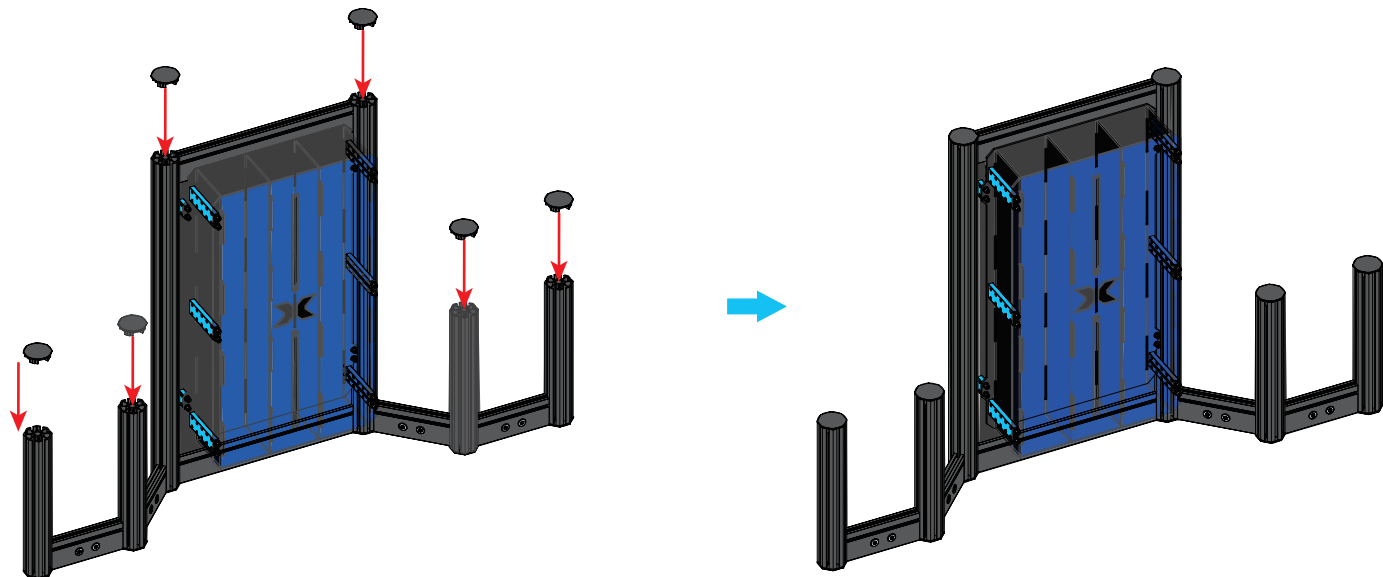



## S03 Assembly S03 搭建

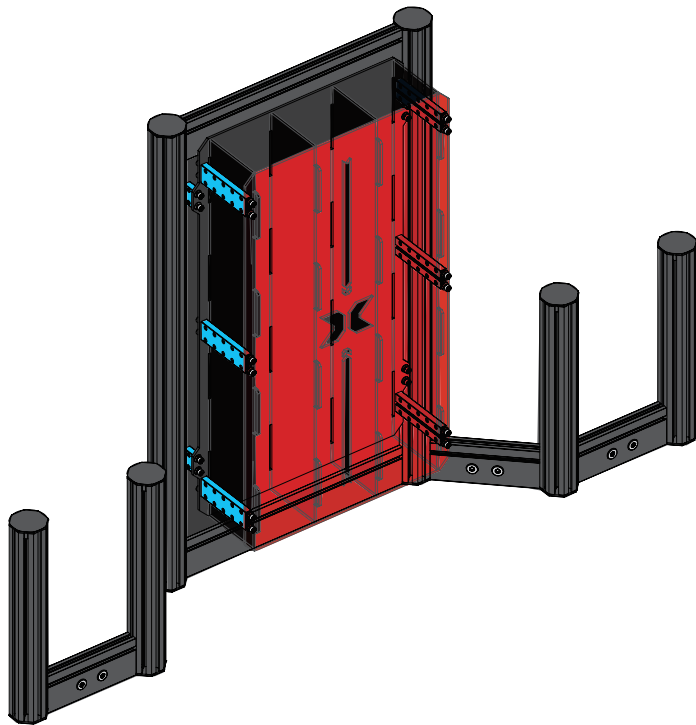

Assemble S03 in the same way.  
以相同的方式组装 S03。

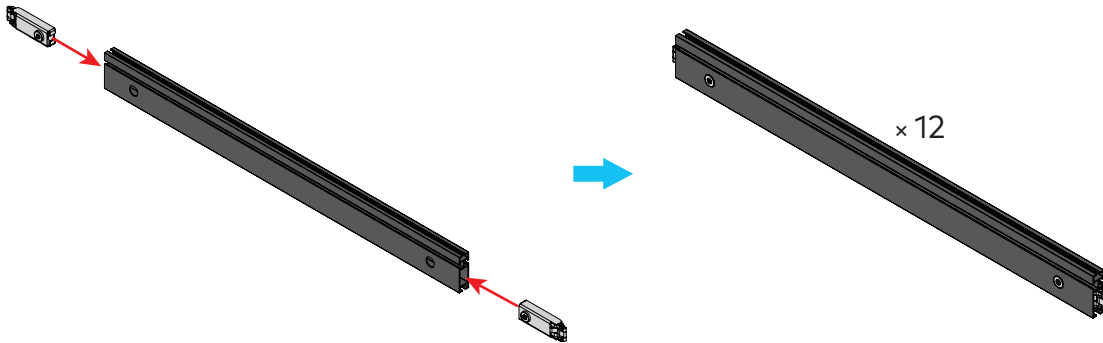

# S04 Assembly S04 搭建

- 12 x  P03
- 24 x  P06



- 4 x  P07
- 4 x  P10

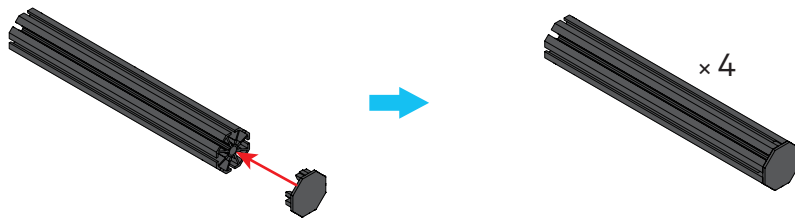

1 × P47

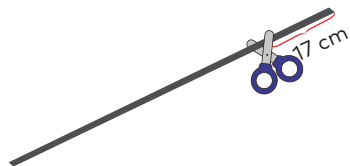

17 cm × 24

1 × P13

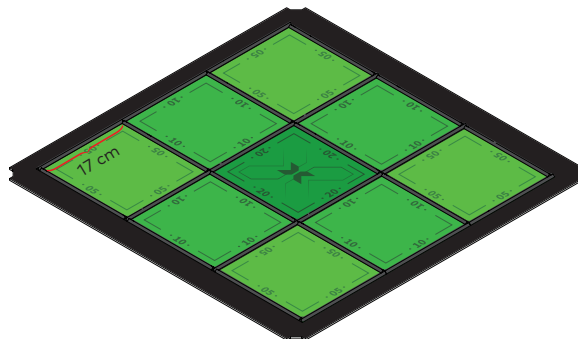
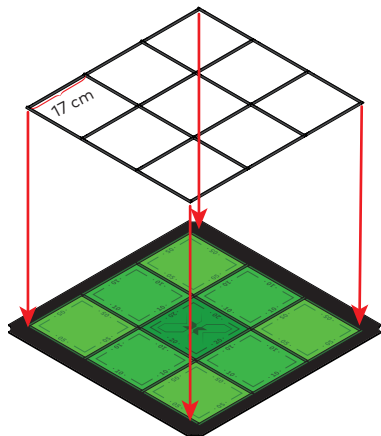
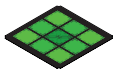

Cut 24 strips of seal, each 17 cm long, and apply them to board B1 as instructed.

用剪刀剪 24 节 17 cm 长的封条, 并按照下图方式贴在 B1 板上。

## S04 Assembly S04 搭建

Align the flat beam with the bottoms of the octagonal pillars and tighten the two flat beam locks.  
对齐扁铝和八棱柱的底部并拧紧 2 个三卡锁。

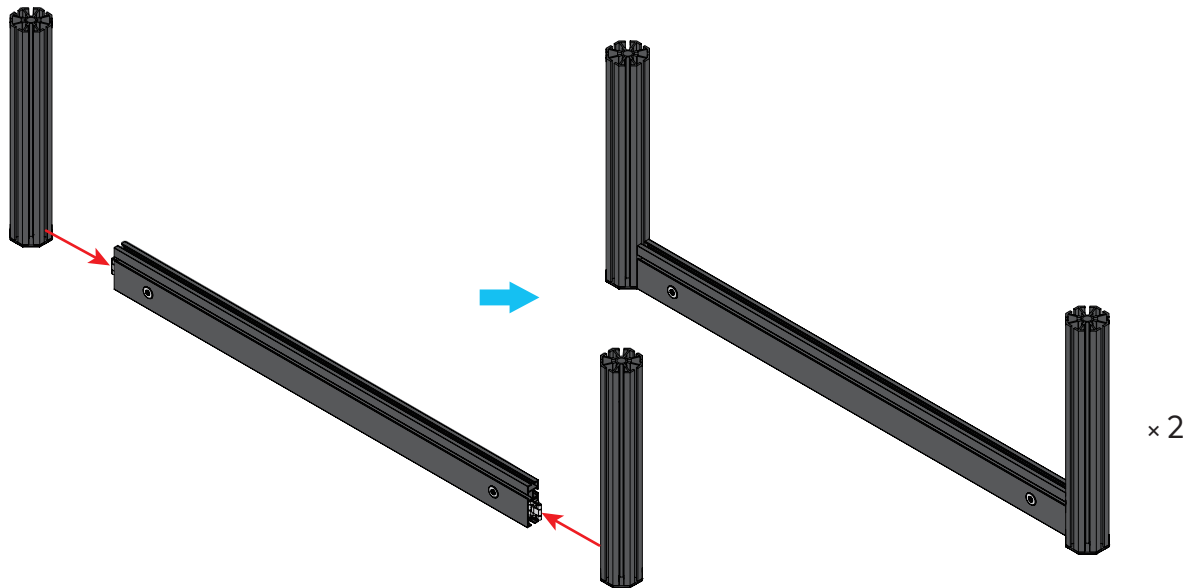

## S04 Assembly S04 搭建

After assembling the flat beams and octagonal pillars, horizontally rotate them 180 degrees.

组装好扁铝和八棱柱后, 将其沿水平方向旋转 180°。

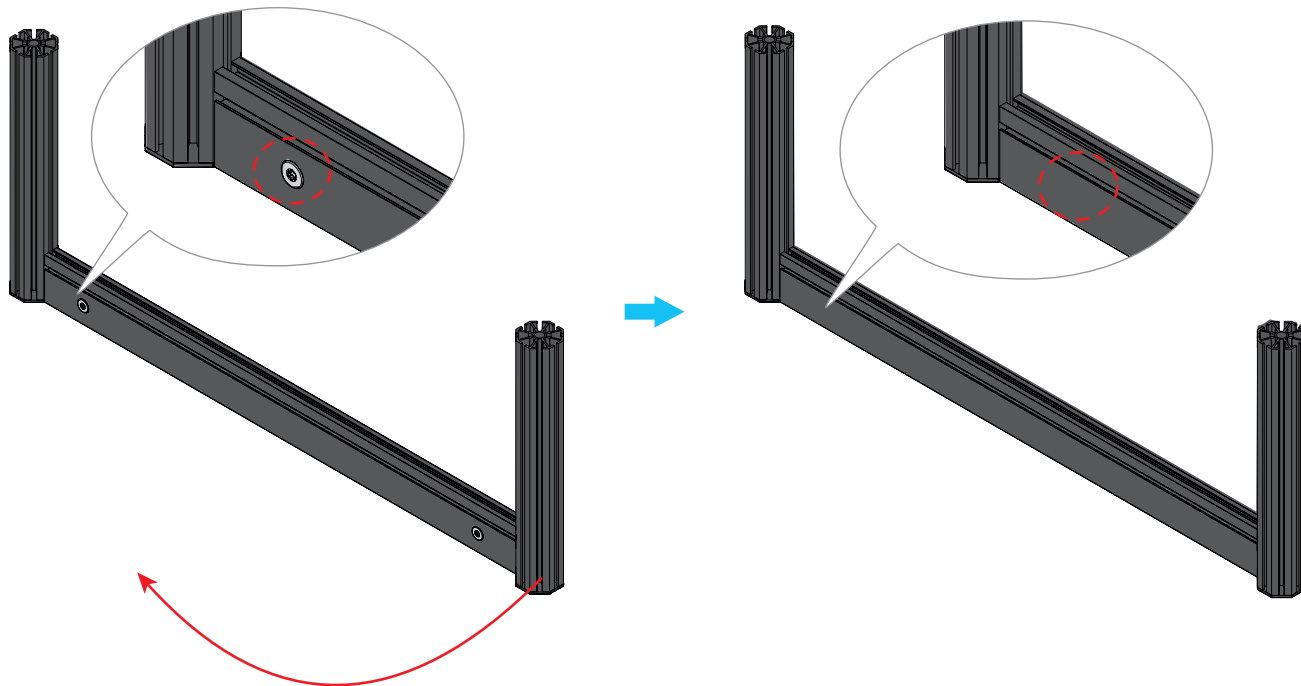

## S04 Assembly S04 搭建

Align the flat beams with the bottoms of the octagonal pillars and tighten the two flat beam locks.  
对齐扁铝和八棱柱的底部并拧紧 2 个三卡锁。

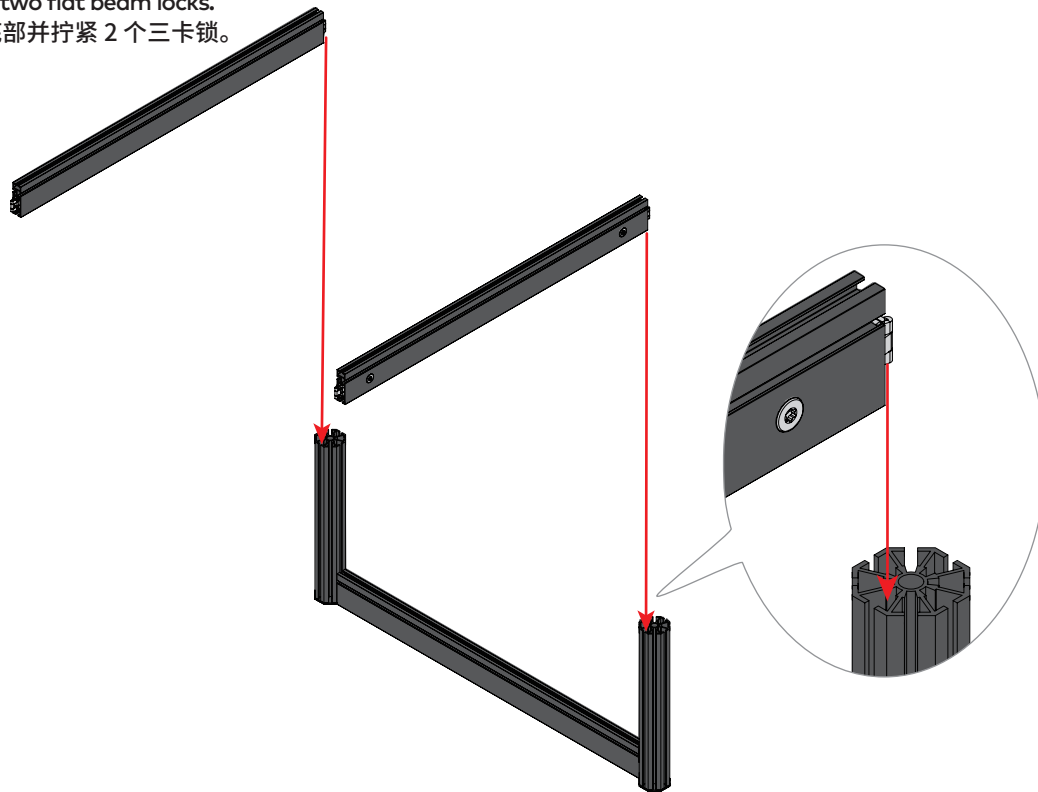

## S04 Assembly S04 搭建

Align the flat beams with the tops of the octagonal pillars and tighten the four flat beam locks.

对齐扁铝和八棱柱的顶部并拧紧 4 个三卡锁。

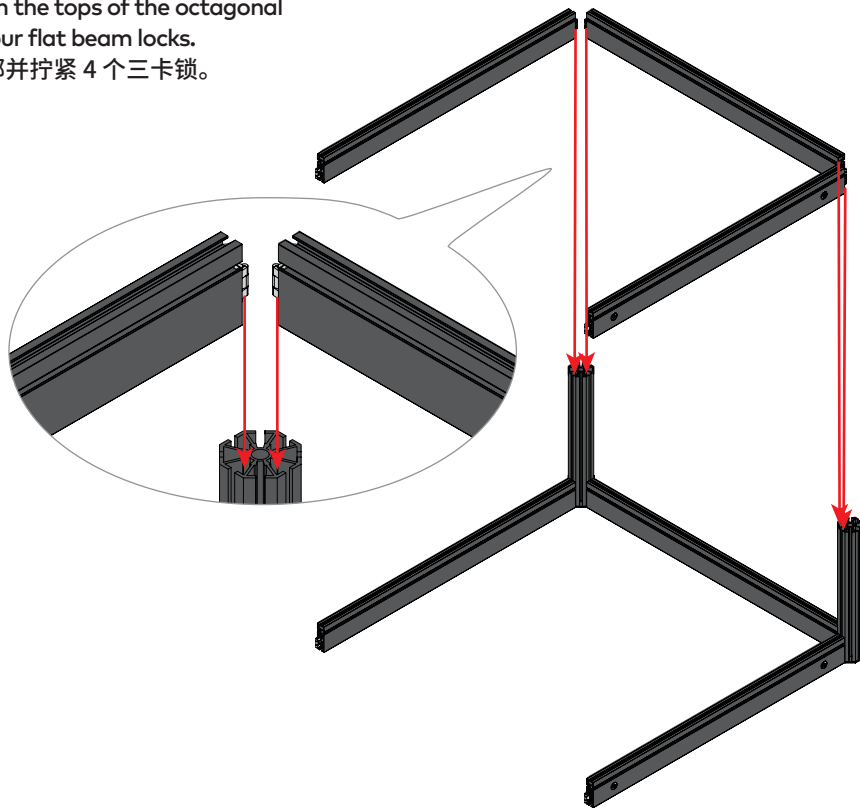

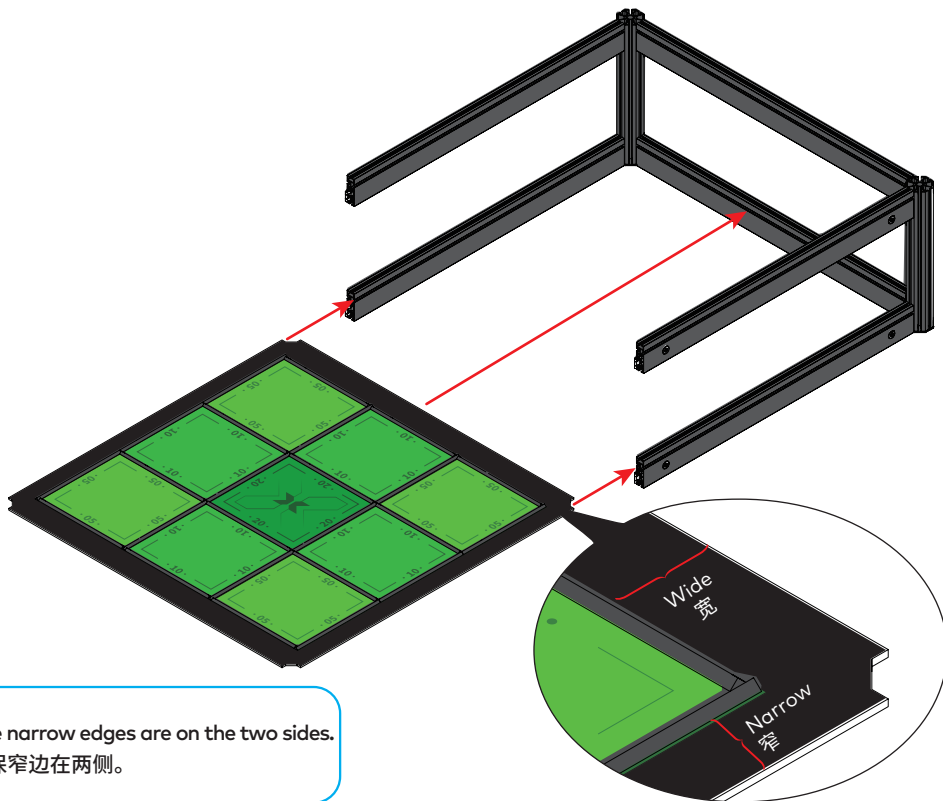

 Ensure the narrow edges are on the two sides.  
安装时确保窄边在两侧。

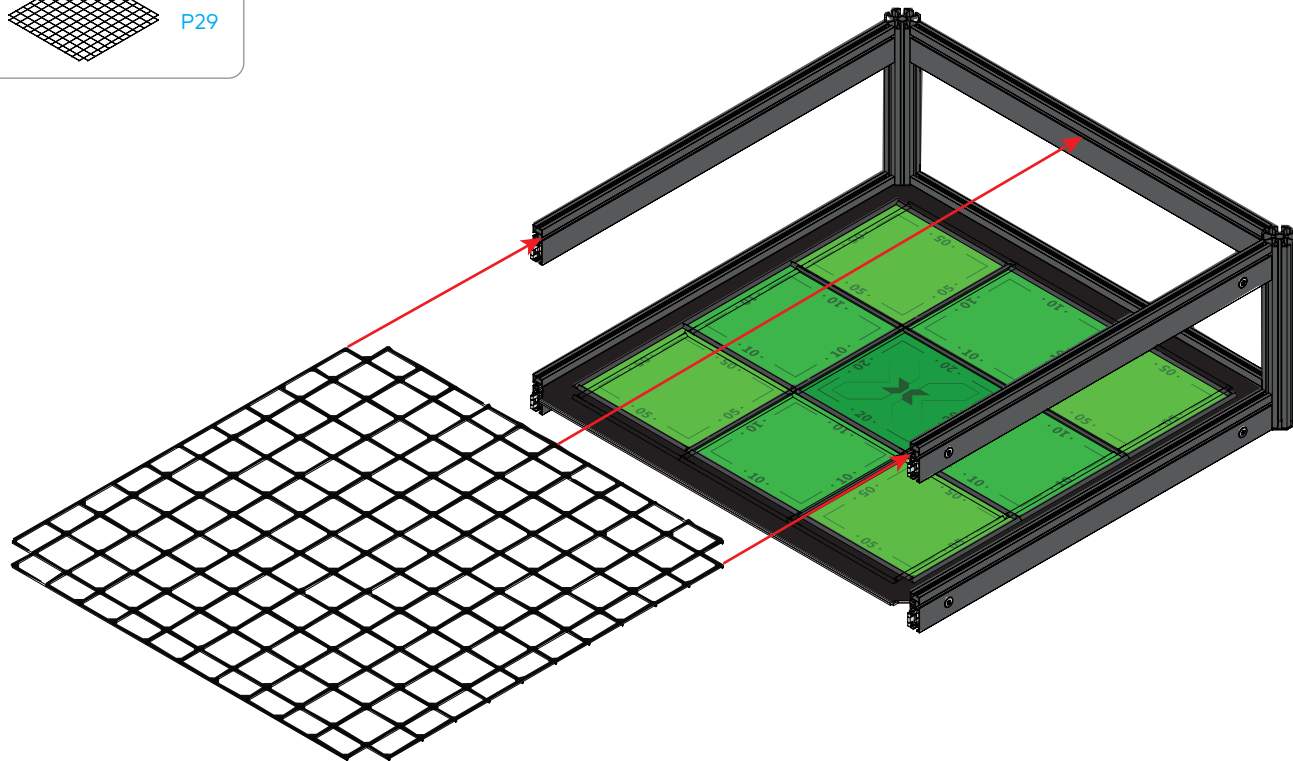
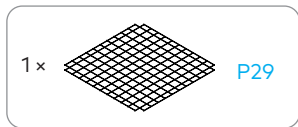

## S04 Assembly S04 搭建

57

Align the flat beams with the tops of the octagonal pillars and tighten the two flat beam locks.  
对齐扁铝和八棱柱的顶部并拧紧 2 个三卡锁。

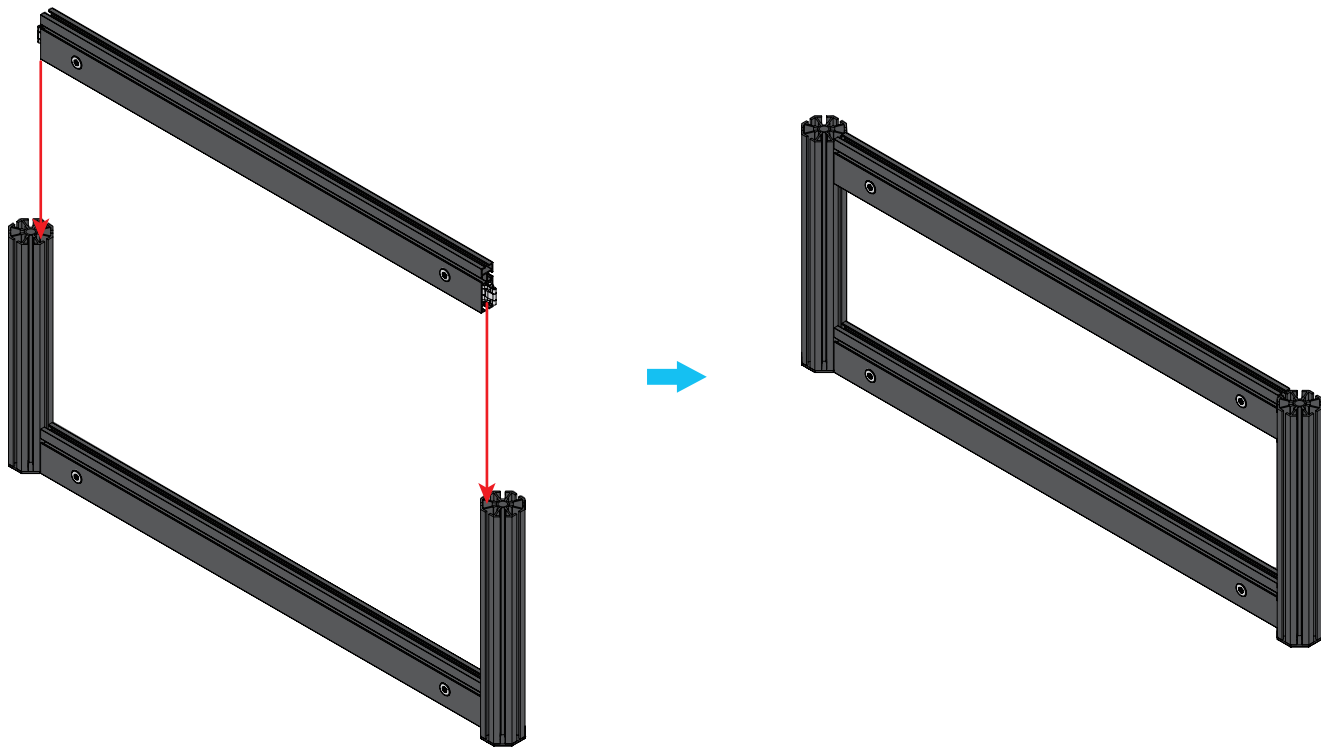





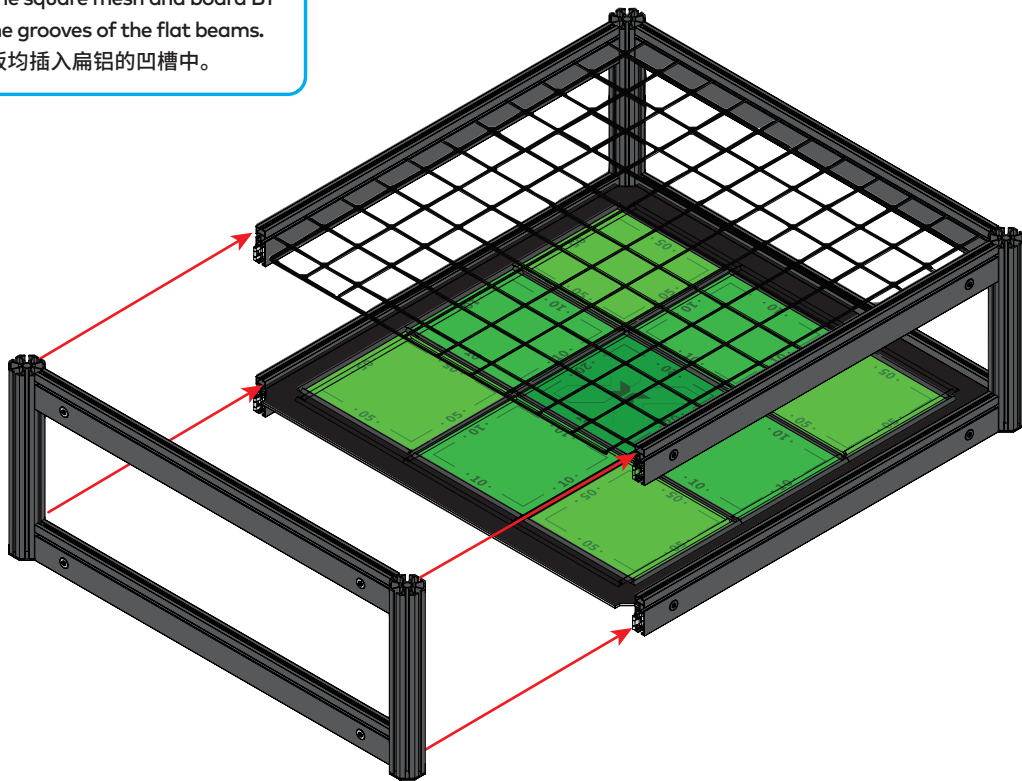

Ensure that both the square mesh and board B1 are inserted into the grooves of the flat beams.  
确保方形网和 B1 板均插入扁铝的凹槽中。

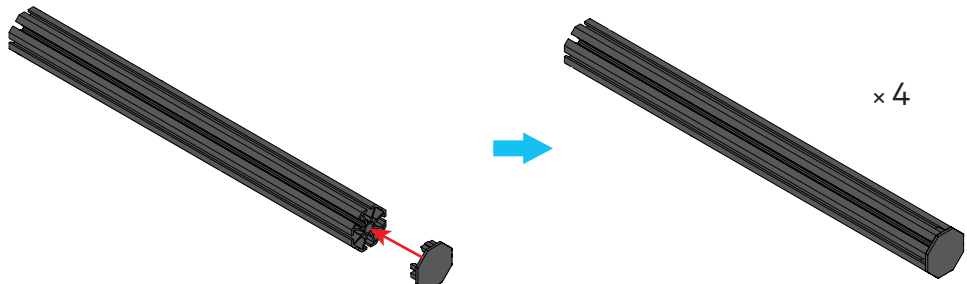

# S04 Assembly S04 搭建

- 4 x  P08
- 4 x  P10



- 8 x  P01
- 16 x  P06

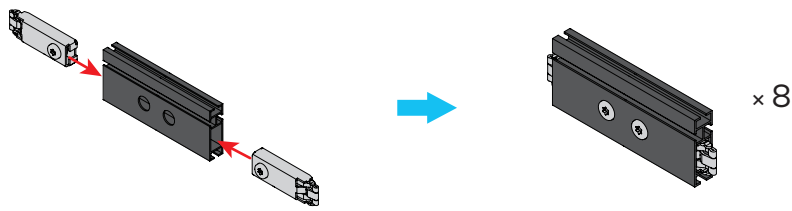

## S04 Assembly S04 搭建

Align the flat beams with the bottoms of the octagonal pillars and tighten the four flat beam locks.

对齐扁铝和八棱柱的底部并拧紧 4 个三卡锁。

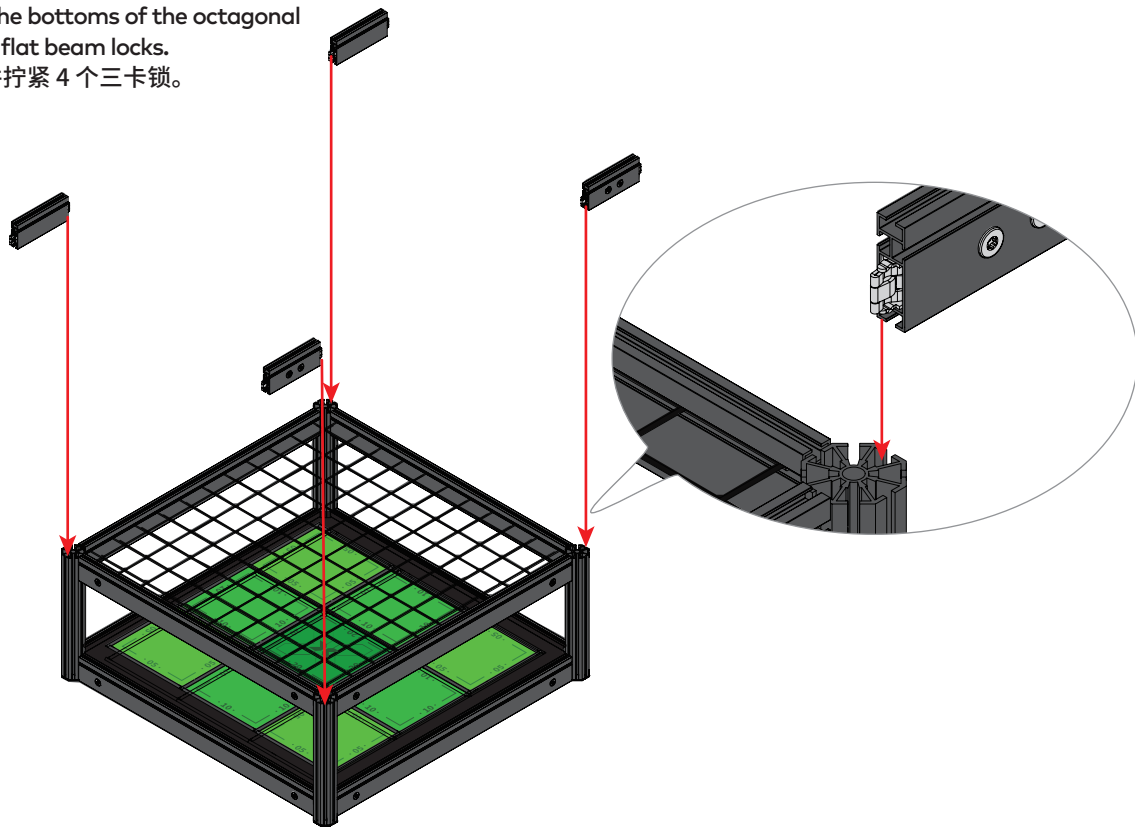

## S04 Assembly S04 搭建

61

Align the flat beams with the tops of the octagonal pillars and tighten the four flat beam locks.

对齐扁铝和八棱柱的顶部并拧紧 4 个三卡锁。

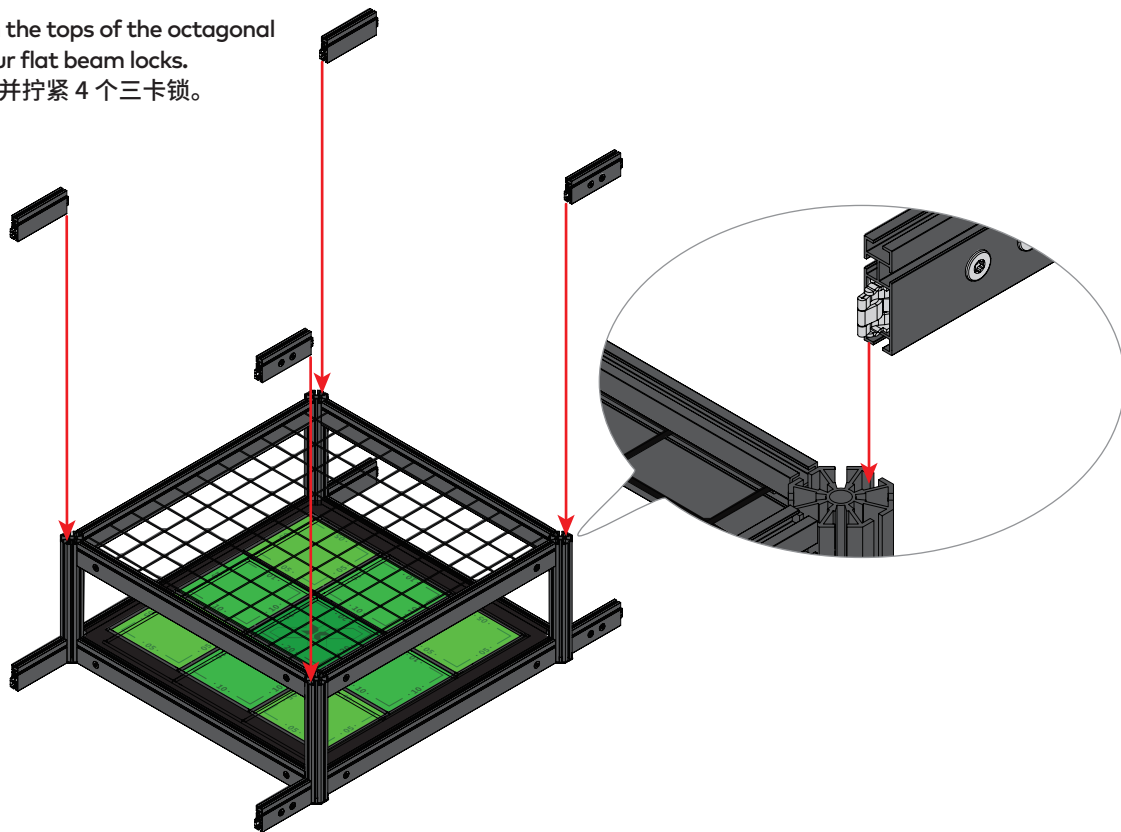

## S04 Assembly S04 搭建

62

2 ×



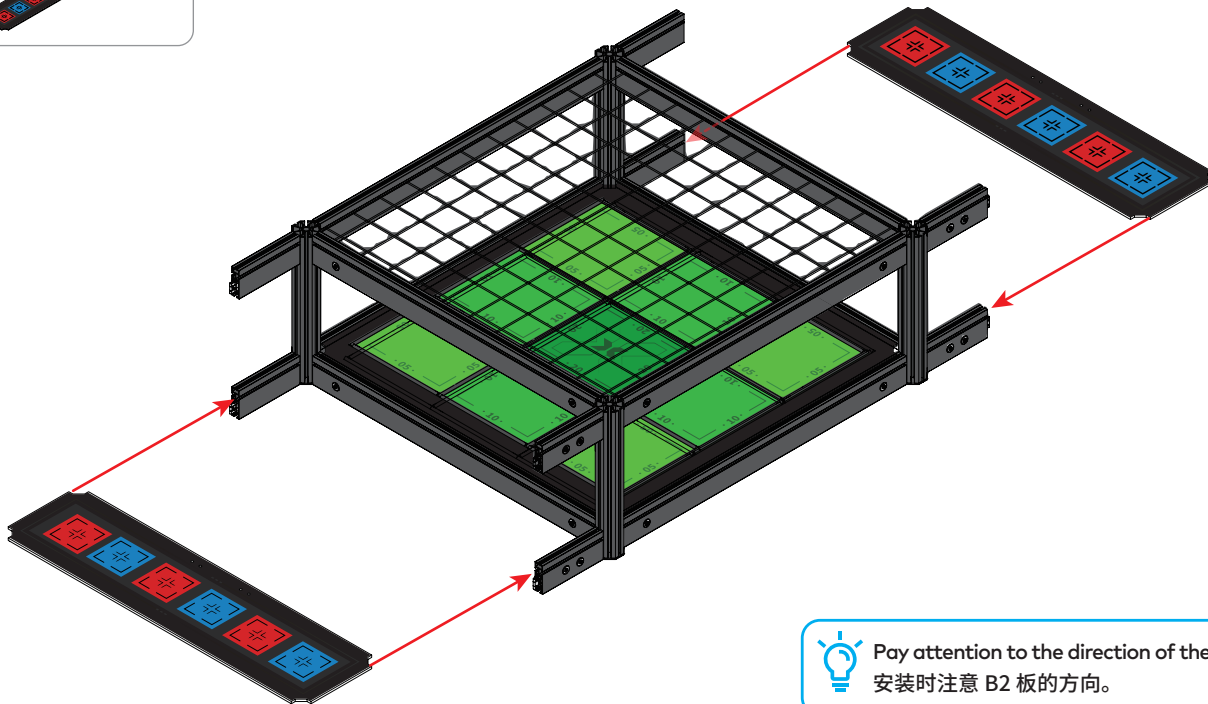

P14



Pay attention to the direction of the boards.  
安装时注意 B2 板的方向。

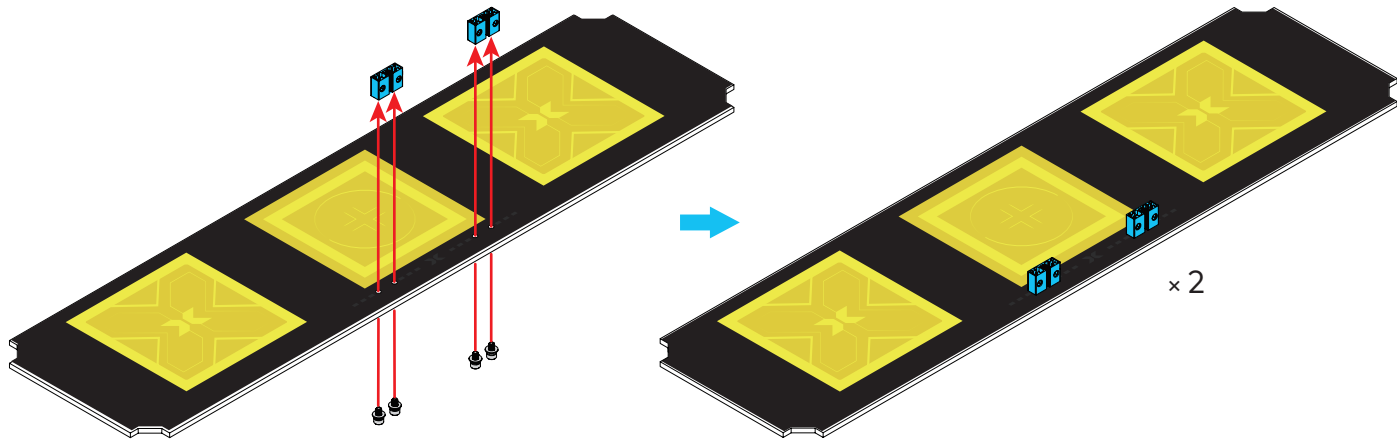

# S04 Assembly S04 搭建

- 2 x  P14
- 4 x  P27
- 8 x  P26

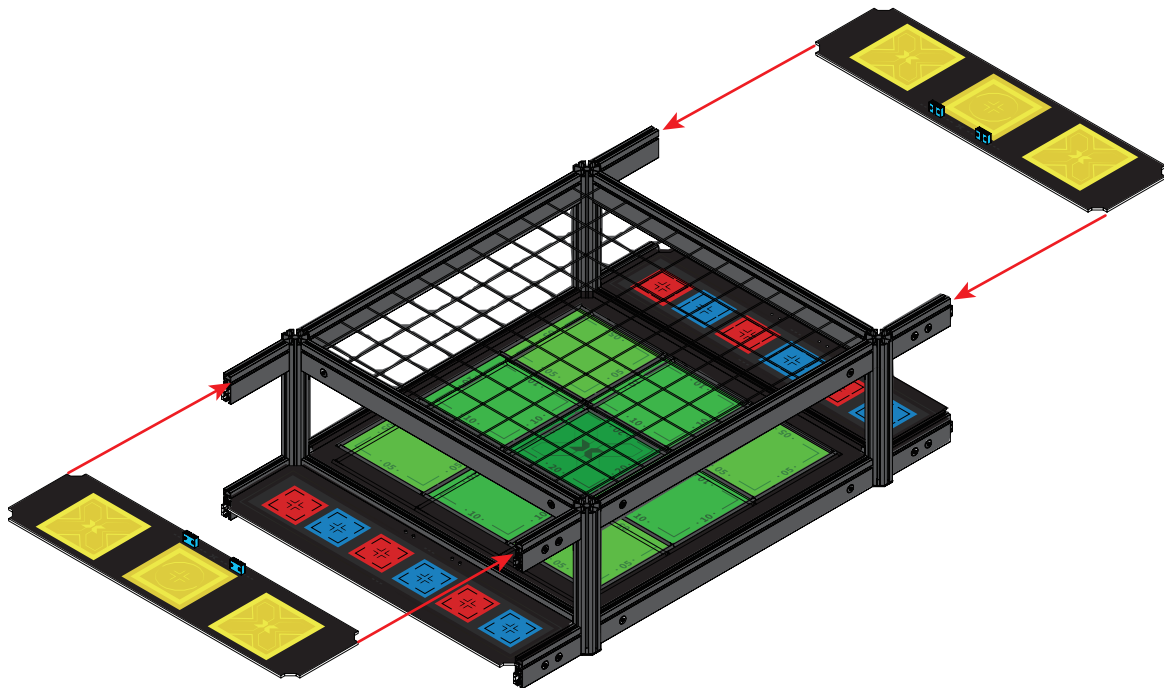



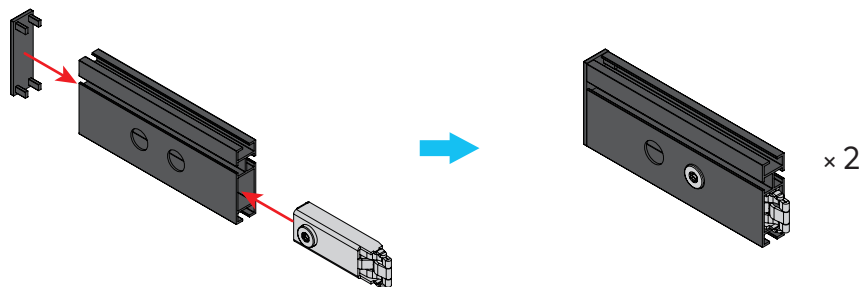

# S04 Assembly S04 搭建

- 2 ×  P01
- 2 ×  P05
- 2 ×  P06



- 2 ×  P01
- 2 ×  P05
- 2 ×  P06

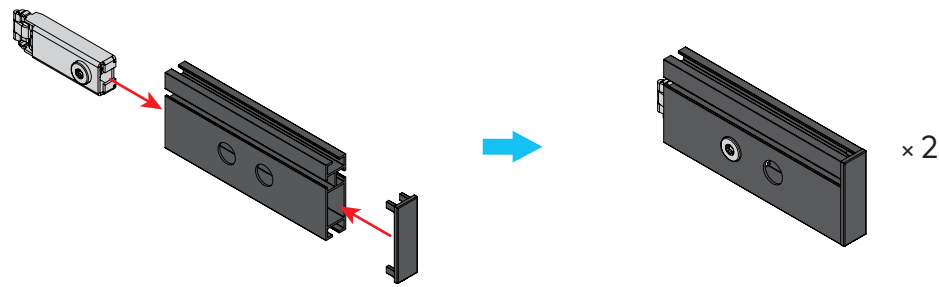

## S04 Assembly S04 搭建

Align the flat beam with the bottoms of the octagonal pillars and tighten the two flat beam locks.  
对齐扁铝和八棱柱的底部并拧紧 2 个三卡锁。

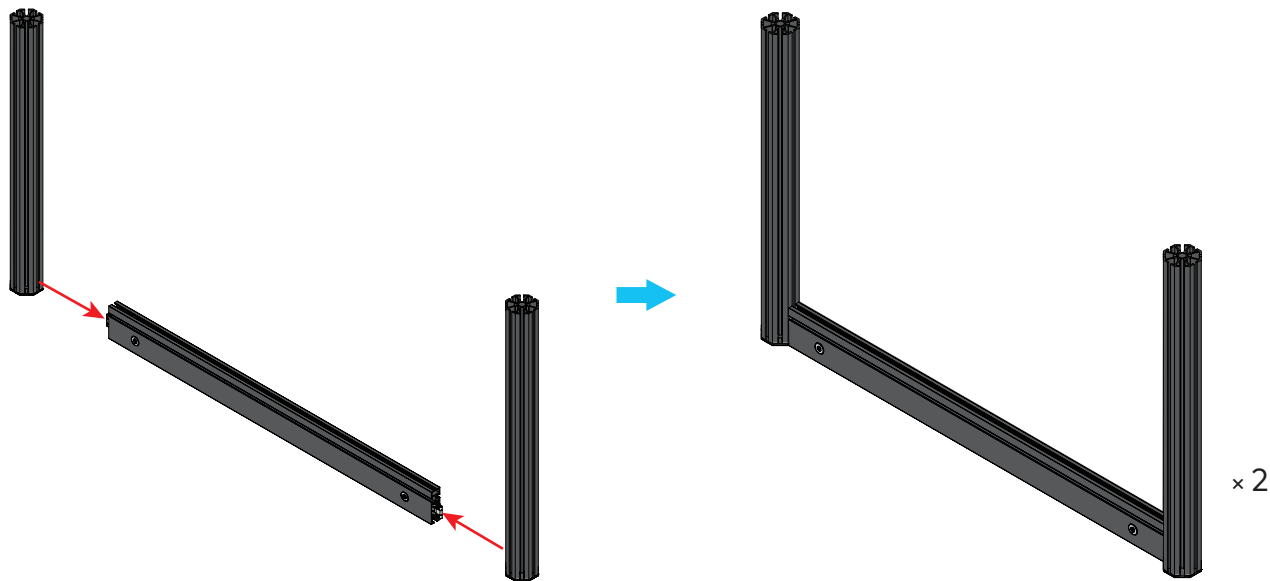



Please do not fully tighten the flat beam locks.  
请不要完全拧紧三卡锁。

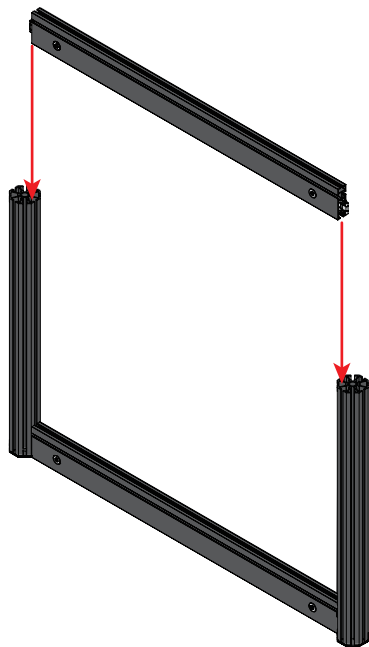

× 2

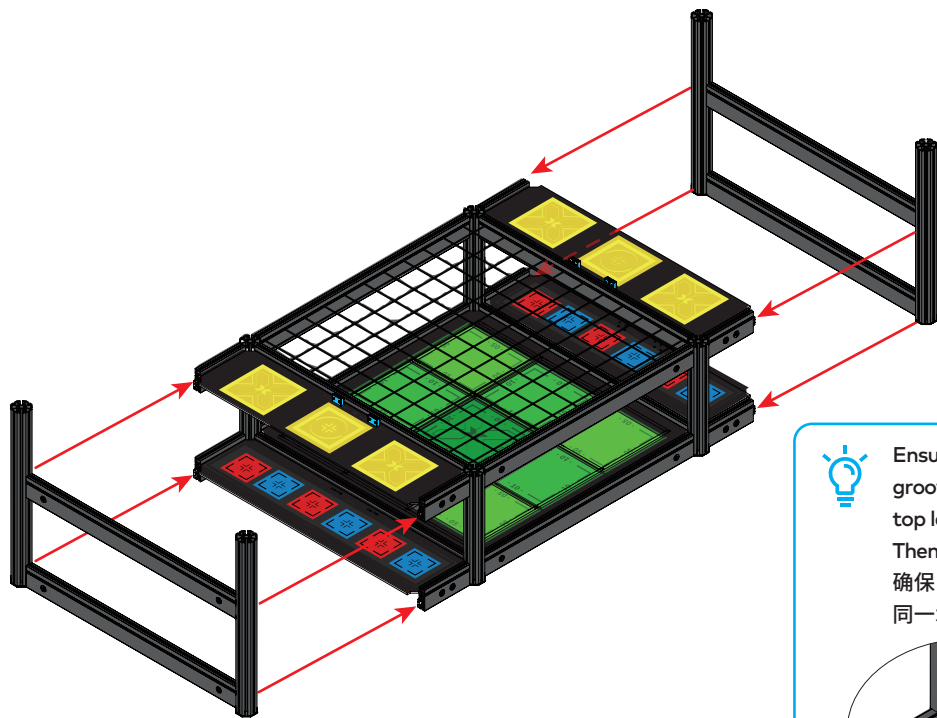

Ensure that the four B2 boards are inserted into the grooves of the flat beams, and the flat beams on the top level are aligned on the same horizontal plane. Then, tighten the flat beam locks.

确保 4 个 B2 板均插入扁铝的凹槽中且顶层的扁铝在同一水平面。然后，拧紧三卡锁。

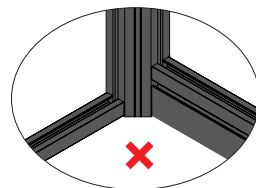
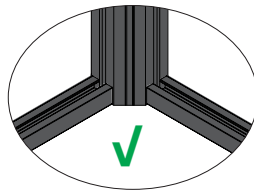

## S04 Assembly S04 搭建

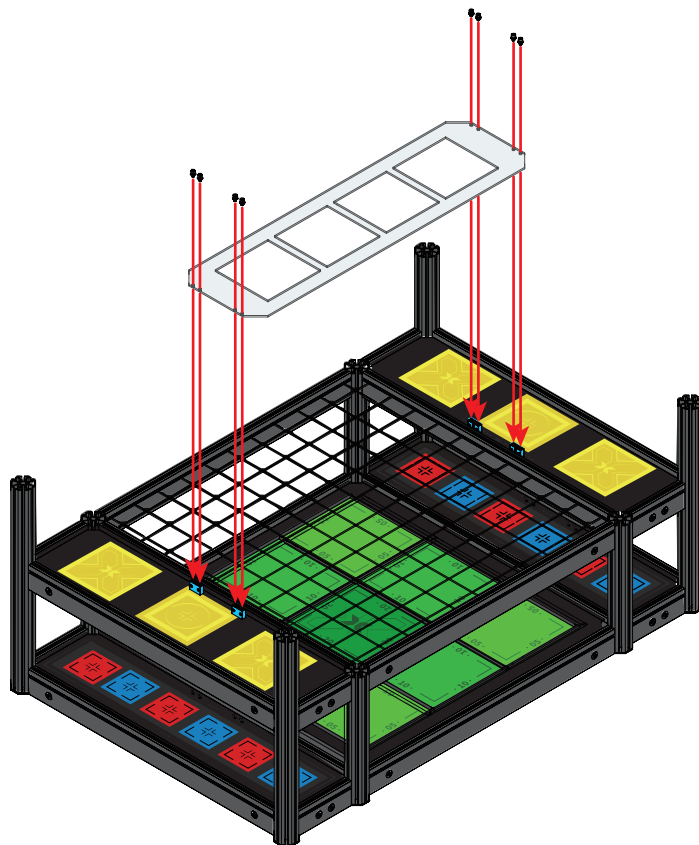
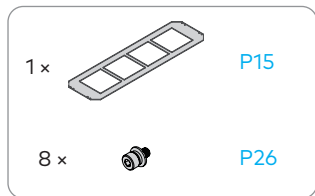

## S04 Assembly S04 搭建

70

Align the flat beams with the tops of the octagonal pillars and tighten the four flat beam locks.

对齐扁铝和八棱柱的顶部并拧紧 4 个三卡锁。

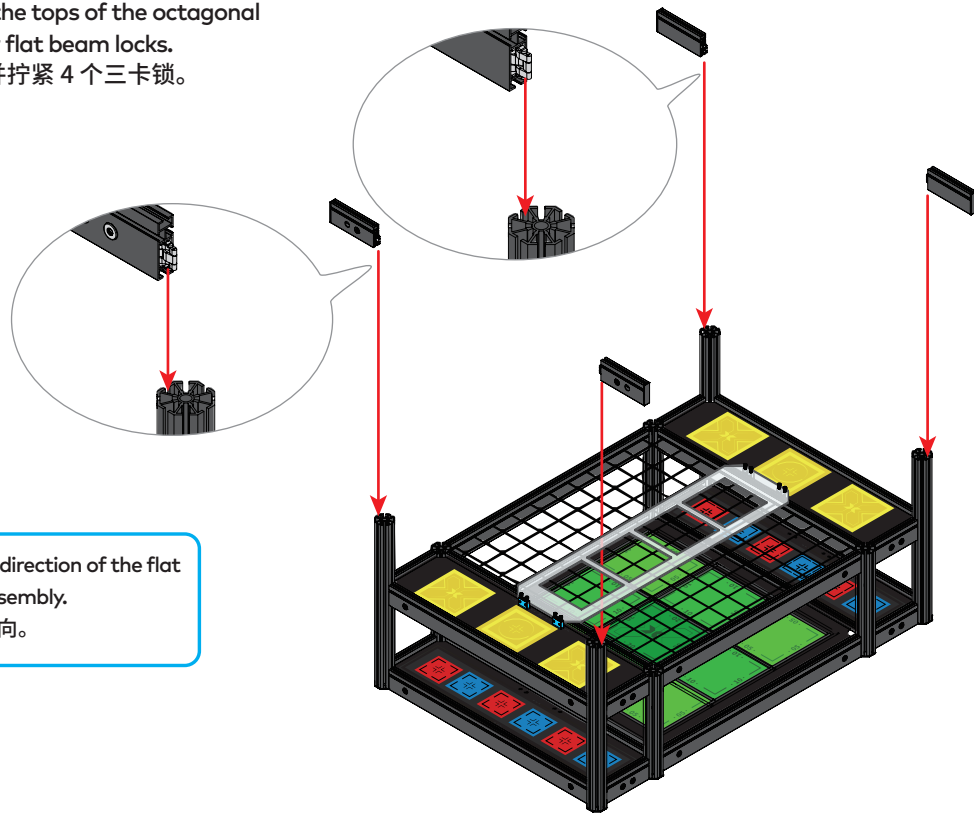

Pay attention to the direction of the flat beams during the assembly.

安装时注意扁铝的方向。

## S04 Assembly S04 搭建

8 ×



P10

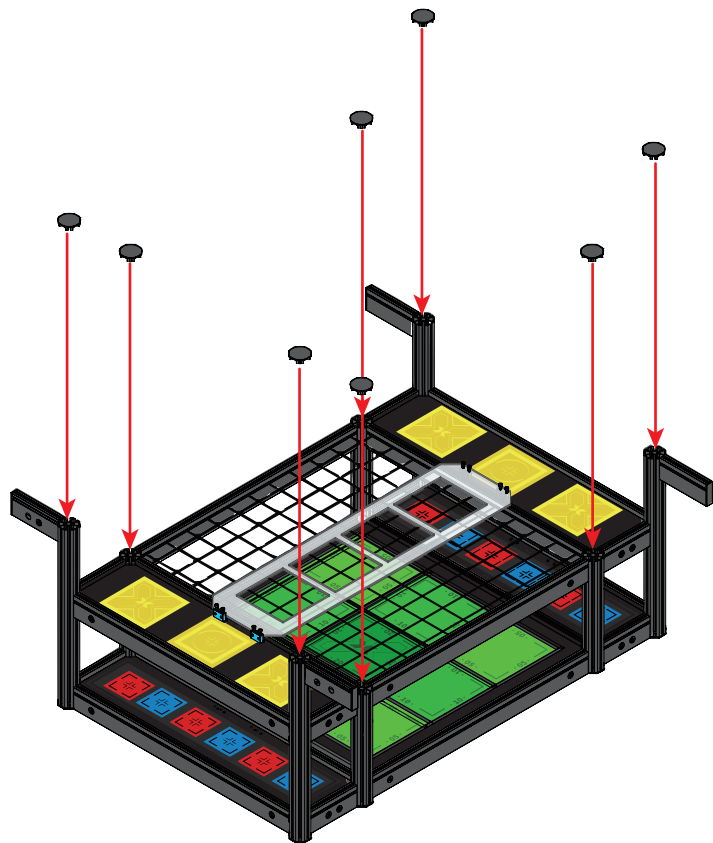

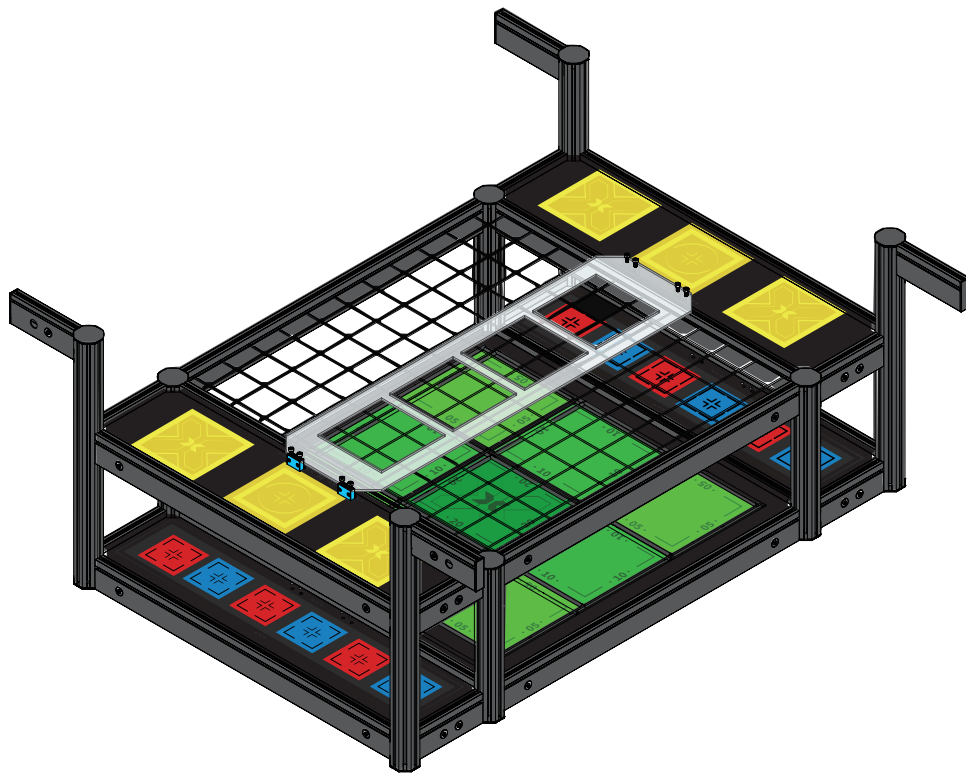

## Arena Assembly 场地搭建

73

1 ×

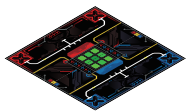

P30

1 ×



P45

Apply the double-sided fabric tape on the competition platform and then paste the map.

在赛台上贴上双面布基胶带，然后贴上地图。

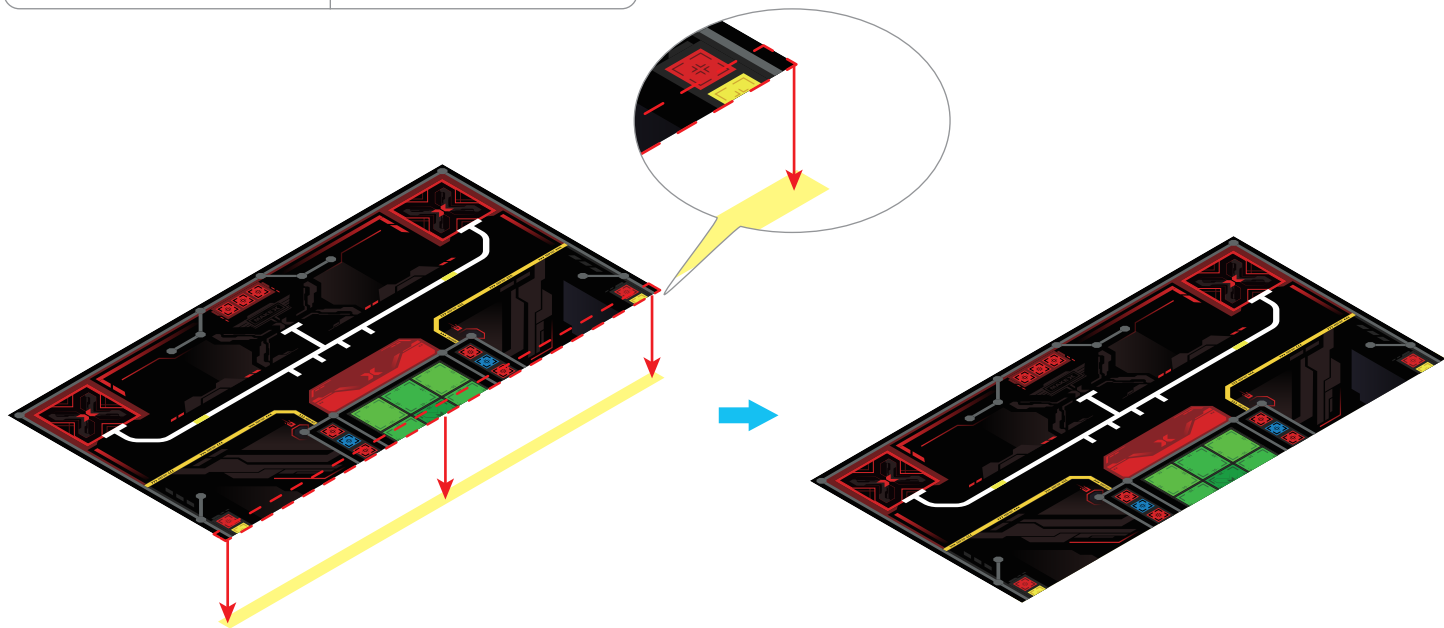

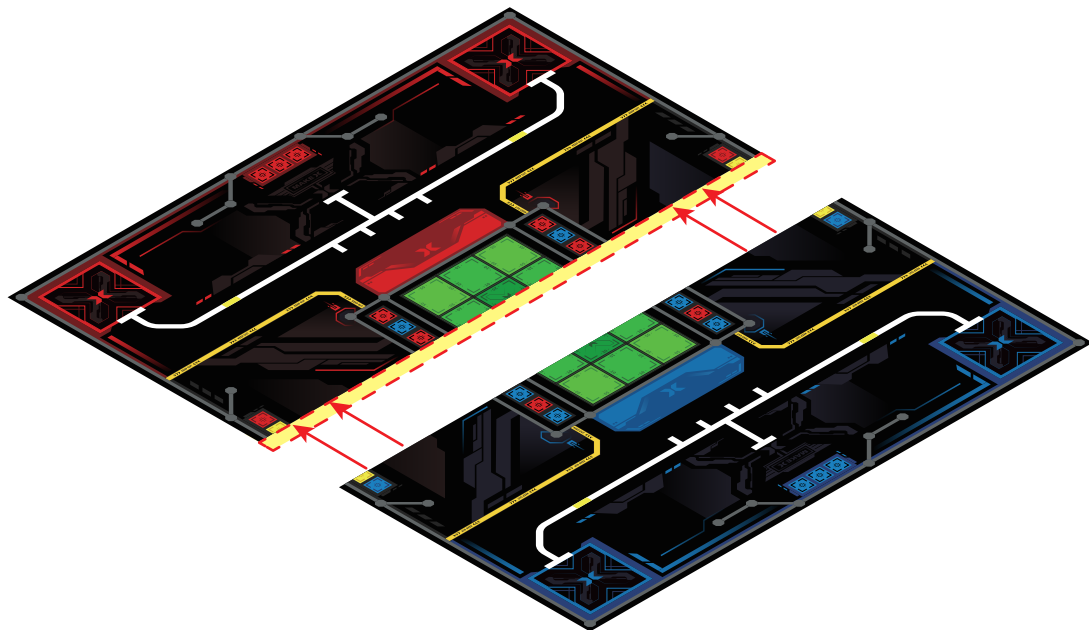

1 ×



P46

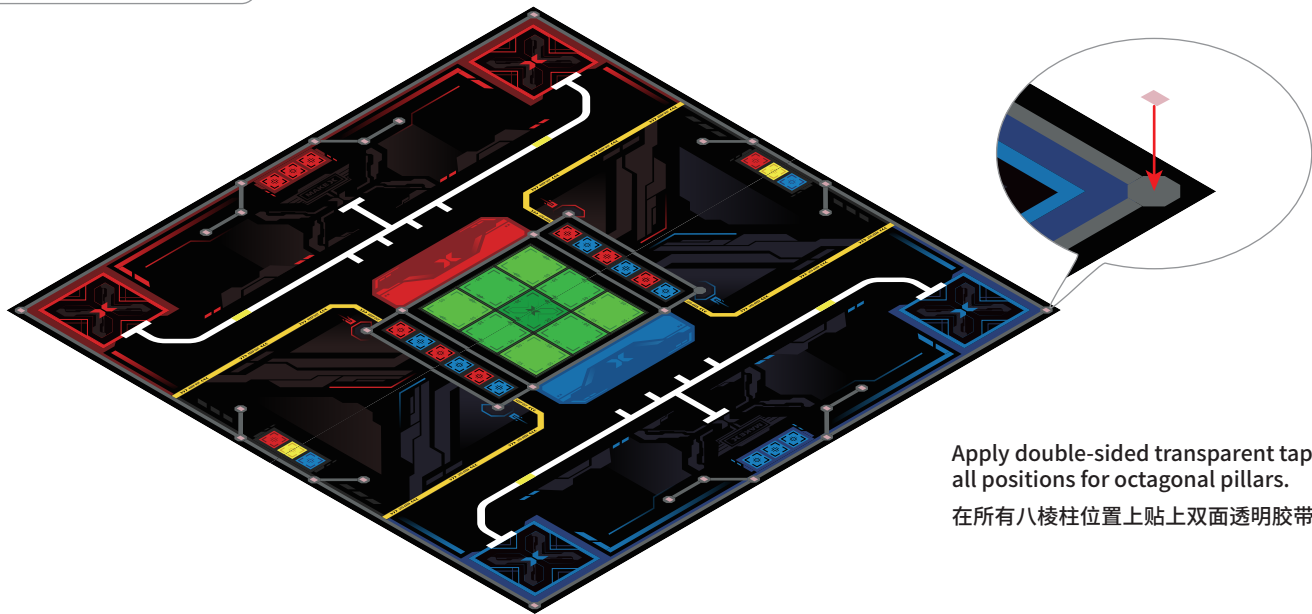

Apply double-sided transparent tape to all positions for octagonal pillars.

在所有八棱柱位置上贴上双面透明胶带。



Before installation, remove the release liner of the double-sided transparent tape from the positions for relevant octagonal pillars.

安装前,请撕下相关八棱柱位置胶带的离型纸。

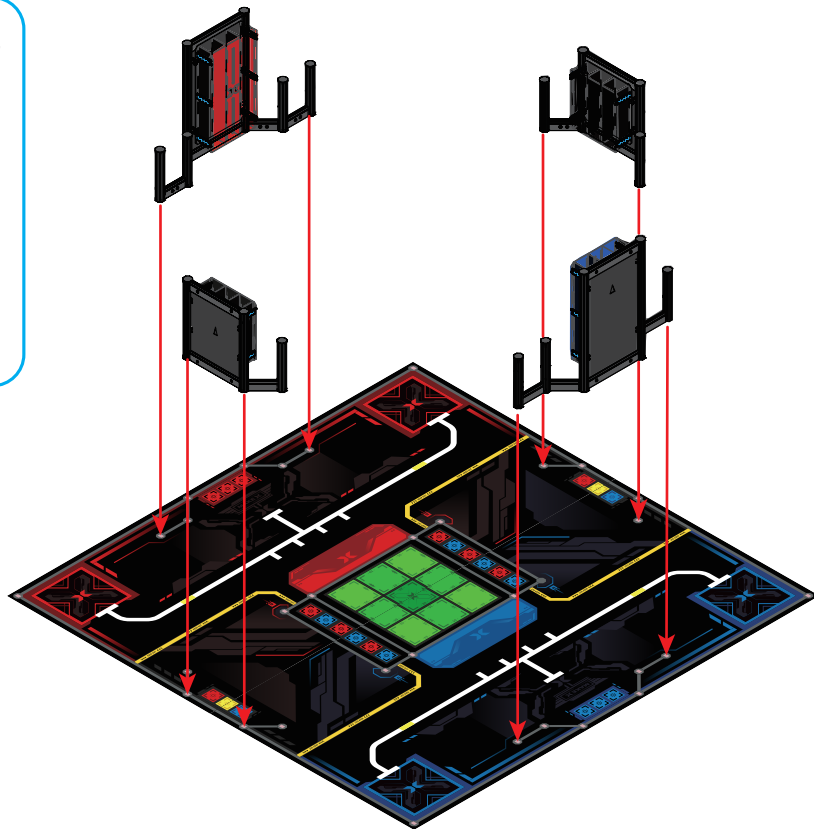
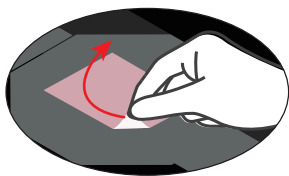

## Arena Assembly 场地搭建

Align the flat beams of the frame with the bottoms of the octagonal pillars of S01 to S03, and tighten the frame's flat beam locks.  
对齐外框扁铝和 S01~S03 的八棱柱底部,并锁紧外框的三卡锁。

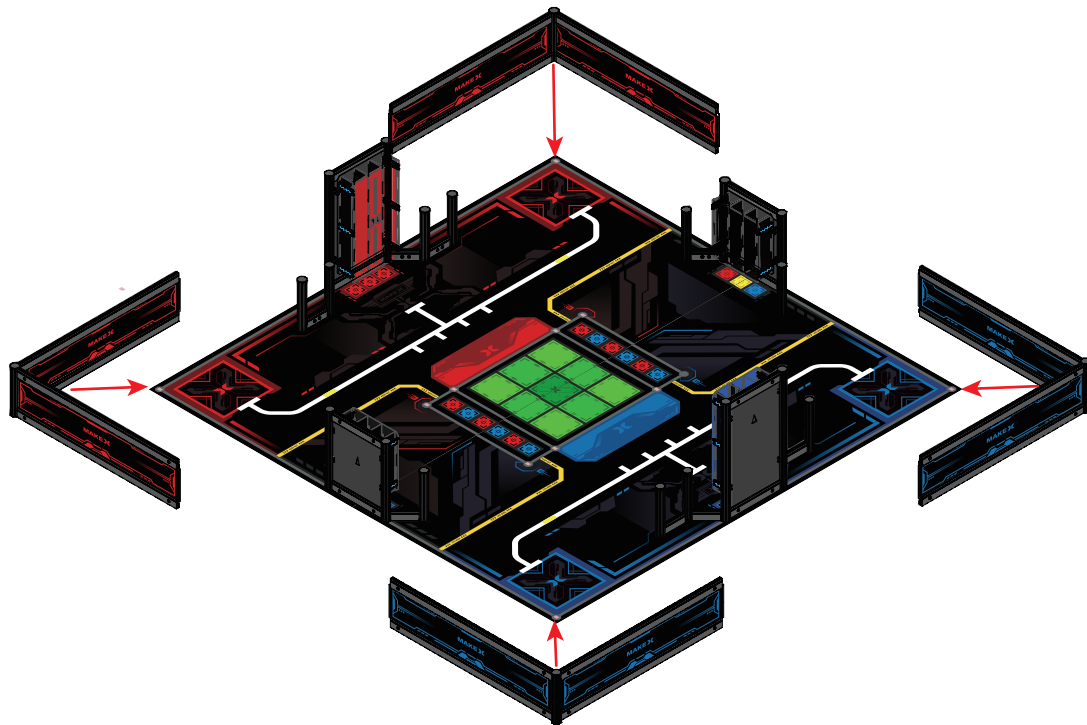

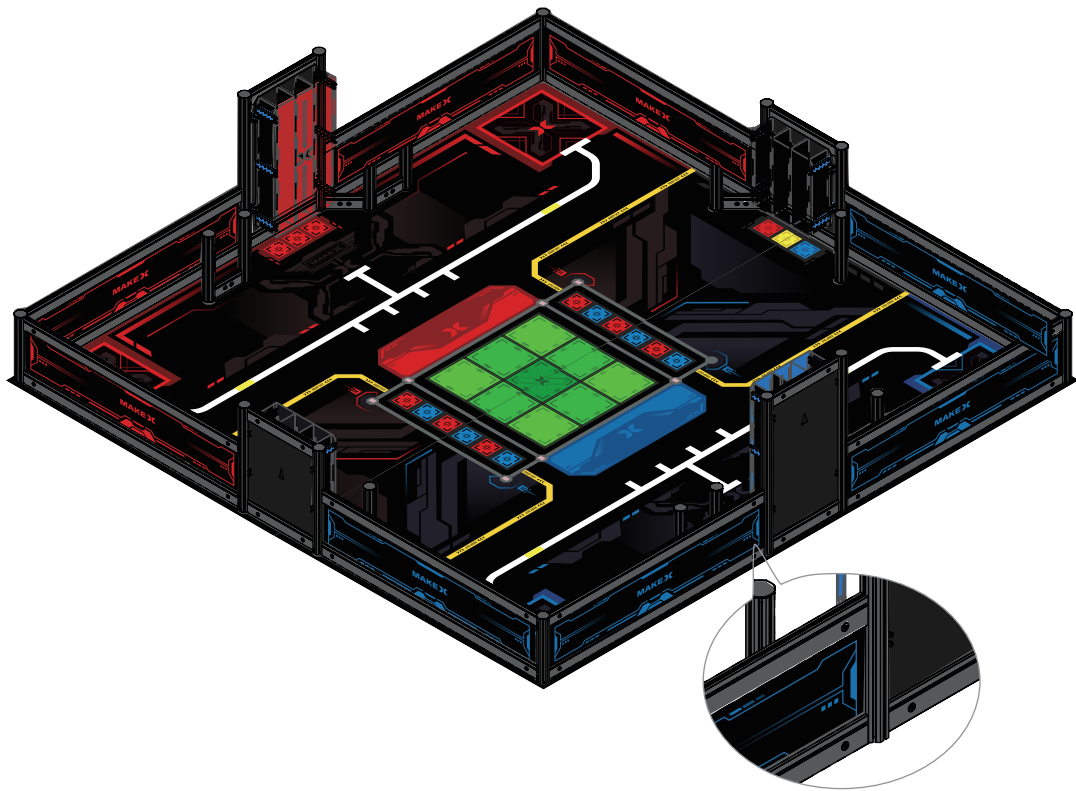



## Arena Assembly 场地搭建

Remove the release liner of the double-sided transparent tape from the positions for relevant octagonal pillars, and then align and fix S04 on the map.

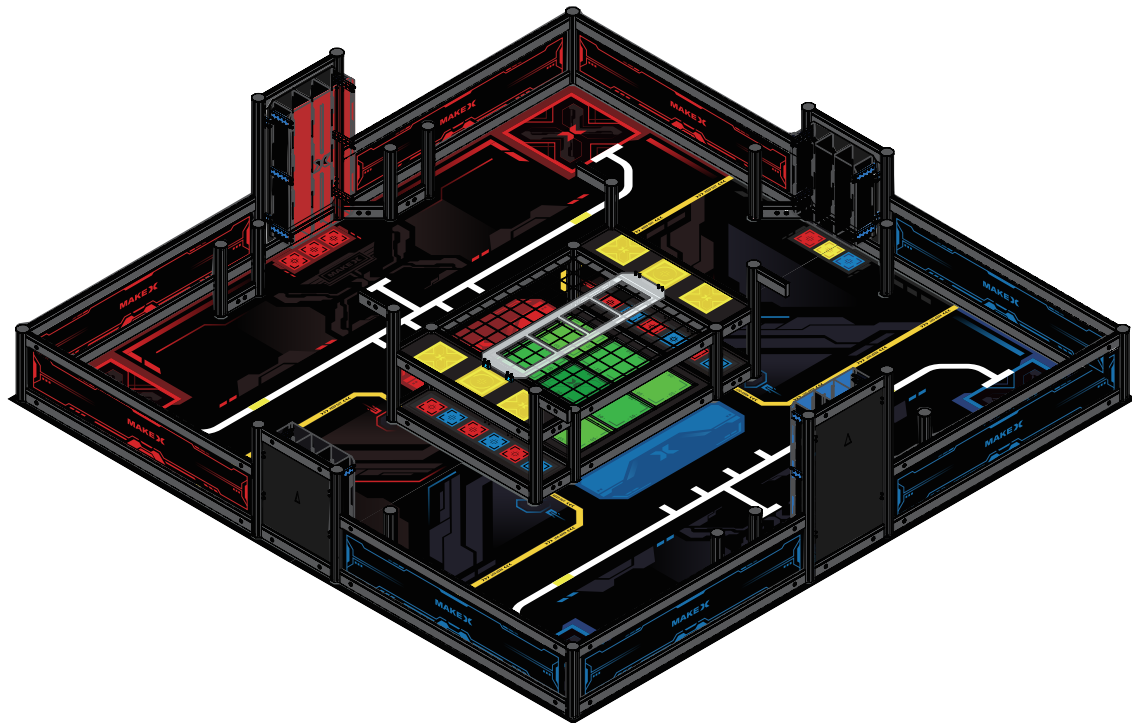
对准地图上的位置, 撕下八棱柱位置的离型纸, 并将 S04 固定在地图上。



1 ×  P34

1 ×  P42

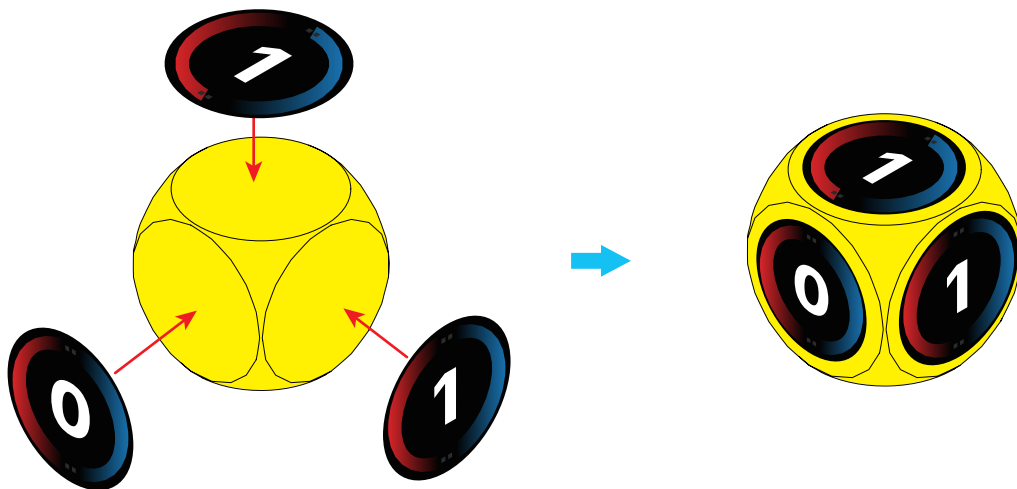

## Item preparation and placement 道具准备和摆放

Horizontally rotate the cube 180 degrees.

将方块沿水平方向旋转 180°。

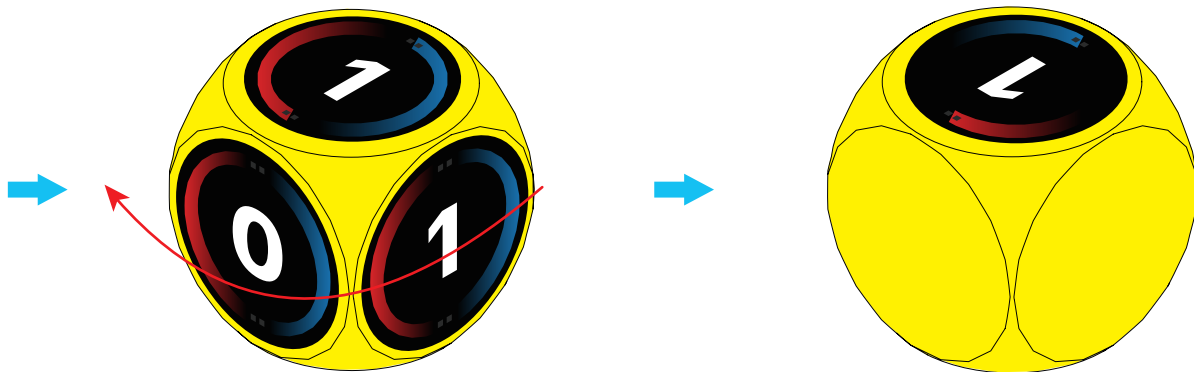

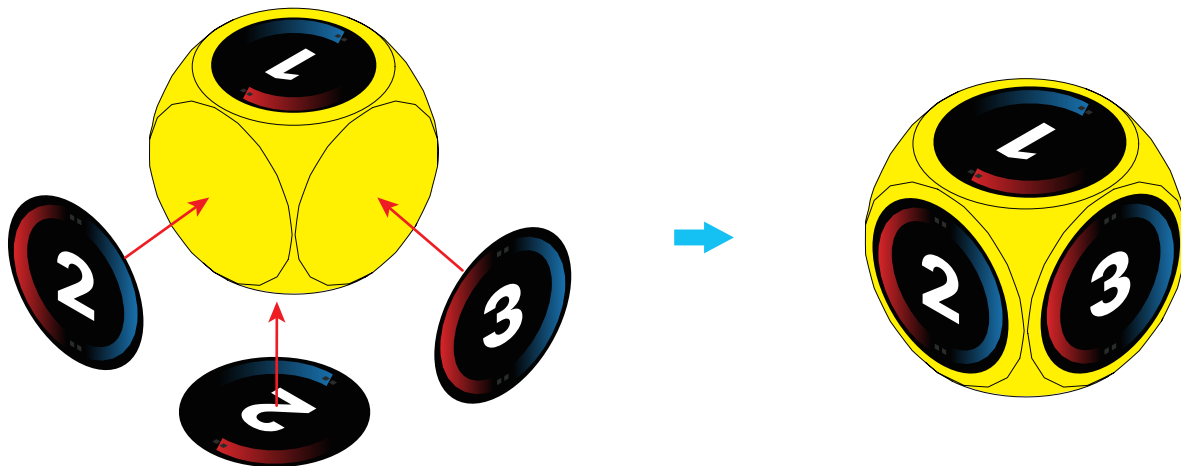

## Item preparation and placement 道具准备和摆放

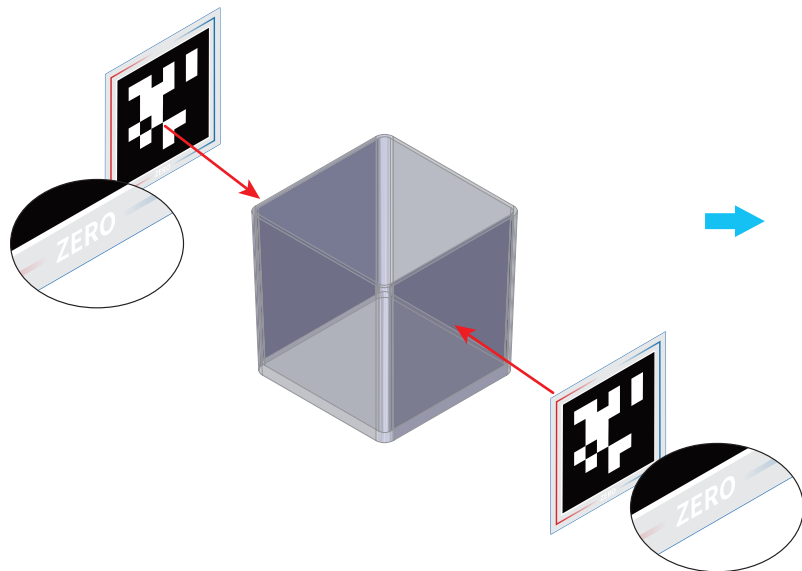
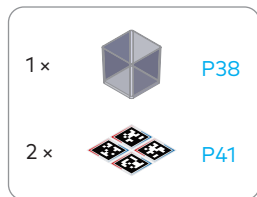

Align the top edge of the sticker with that of the transparent square box.

粘贴时, 贴纸的上边缘与透明方形盒的上边缘对齐。

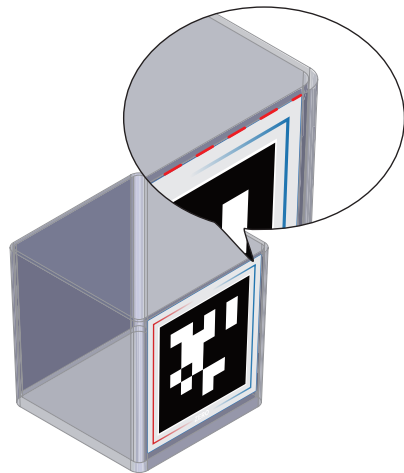

## Item preparation and placement 道具准备和摆放

Apply stickers ONE, TWO, and THREE in the same way.

以同样的方式粘贴贴纸 ONE、TWO 和 THREE。

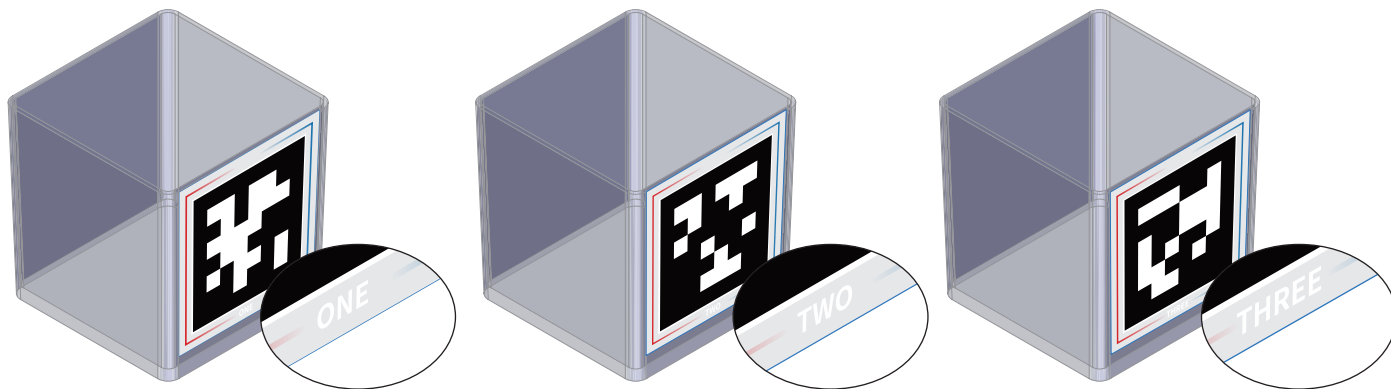

# Item preparation and placement 道具准备和摆放

- 8 x  P25
- 4 x  P41

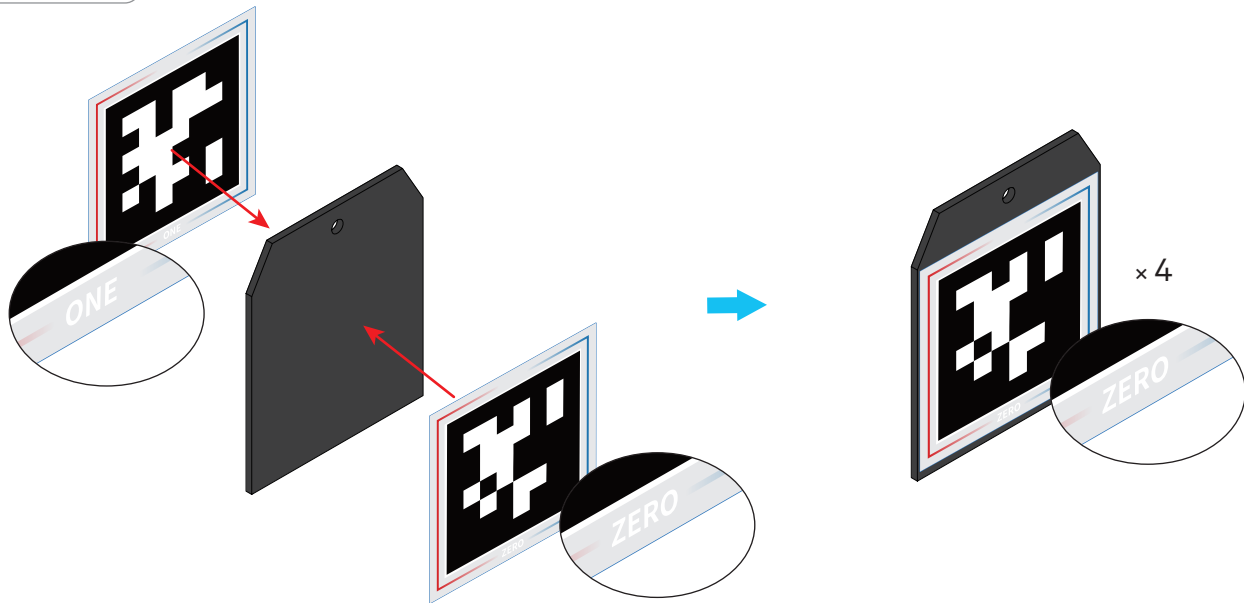

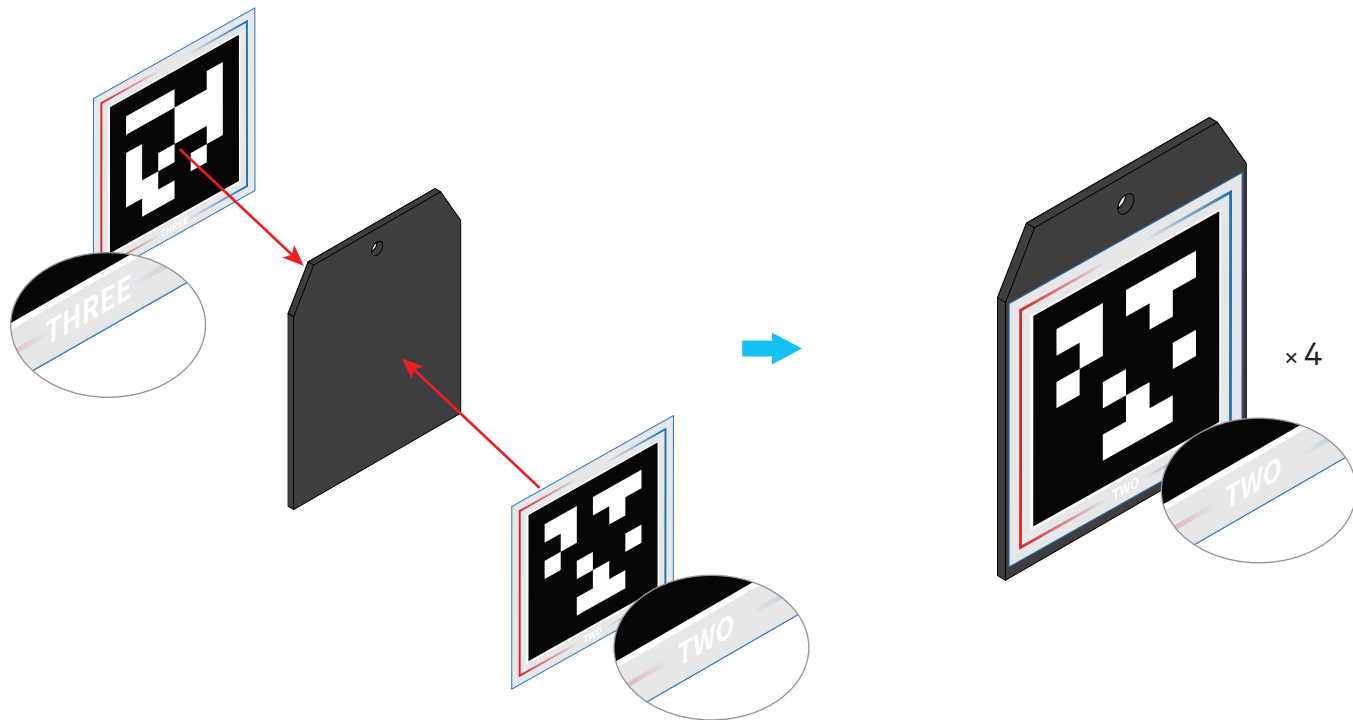

# Item preparation and placement 道具准备和摆放

4 ×  P40

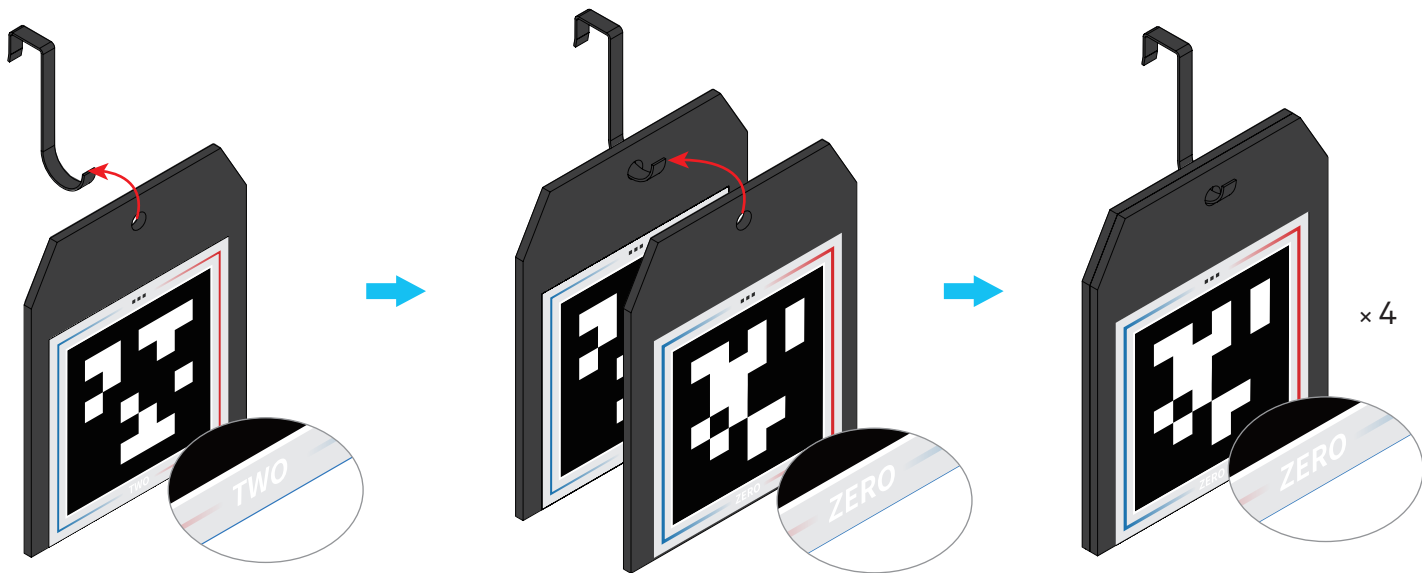



# Item preparation and placement 道具准备和摆放

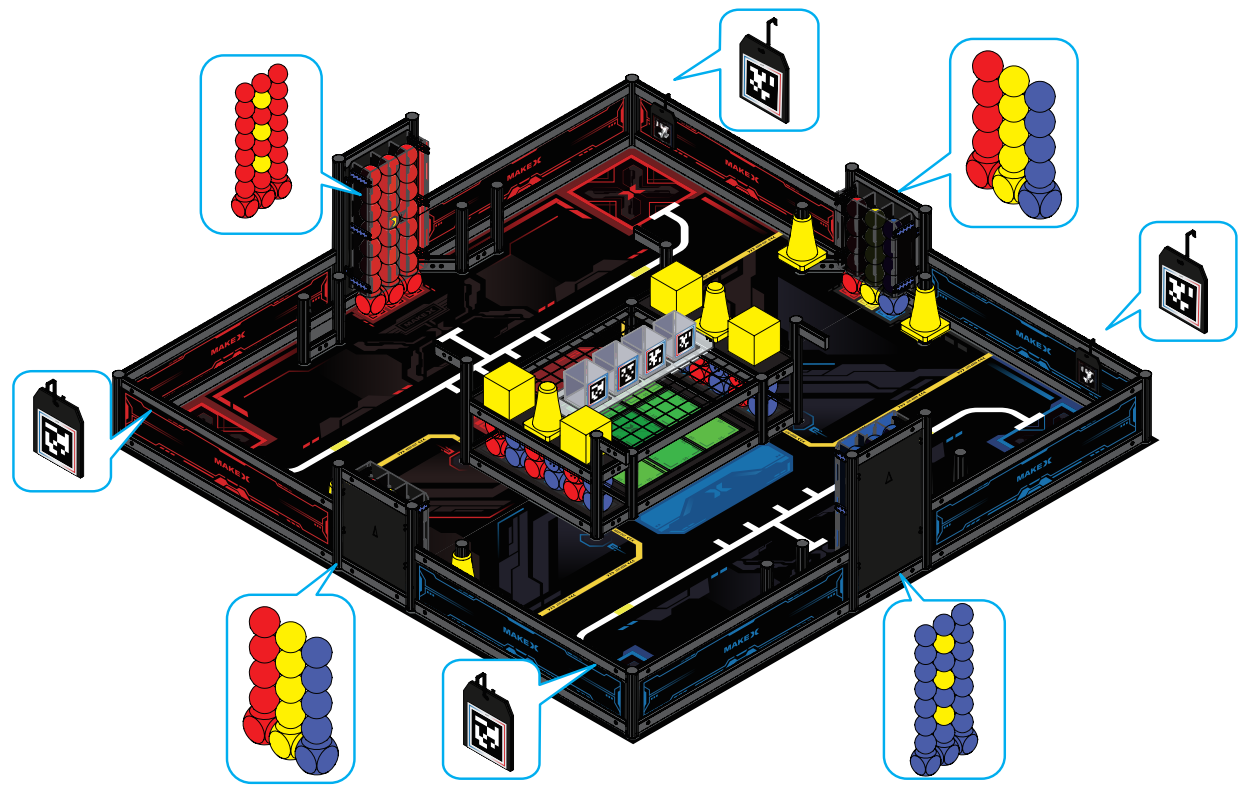

**MAKE X**